

S SERIES AIR HANDLER INSTALLATION INSTRUCTIONS

GENERAL

These instructions are intended as a general guide and do not supersede local codes in any way. Consult with authorities having jurisdiction before installation.

ADP S Series air handlers are suitable for closet or flush mount installations and are designed for electrical heat installation with a matched remote outdoor unit. These units are designed for indoor installations only.

The following words are used throughout this manual to identify levels of hazard seriousness:

DANGER - Immediate hazards that WILL result in severe personal injury or death.

WARNING - Hazards or unsafe practices COULD result in severe personal injury or death.

CAUTION - Hazards or unsafe practices COULD result in minor personal injury or product or property damage.

REQUIREMENTS

The installation of the air handler, field wiring, warm air ducts, etc. must conform to the requirements of the National Electrical Code, ANSI/NFPA No. 70 (latest edition) in the United States, and any state laws, and local ordinances (including plumbing or wastewater codes). Local authorities having jurisdiction should be consulted before installation is made. Such applicable regulations or requirements take precedence over the general instructions in this manual.

Install the conditioned air plenum, ducts and air filters (not provided) in accordance with NFPA 90B Standard for the Installation of Warm Air Heating and Air-Conditioning Systems (latest edition).

This unit is certified for installation clearances to combustible material as listed on the unit rating plate. Accessibility and service clearances must take precedence over combustible material clearances.



IMPORTANT

The Clean Air Act of 1990 bans the intentional venting of refrigerant (CFC's and HFC's) as of July 1, 1992. Approved methods of reclaiming must be followed. Fines and/or incarceration may be levied for non-compliance.

RECEIVING

Check equipment for shipping damage. If you find any damage, immediately contact the last carrier.

Check the unit rating plate for unit size, electric heat, coil, voltage, phase etc. to be sure unit matches requirements.

TABLE OF CONTENTS

Installation	2
Condensate Drain	2
Refrigerant Charging Instructions	3
Blower Speed Changes	4
Airflow Data	4
Electrical Data	5
Thermostat Low Voltage Connections	6
Electrical Wiring Diagrams	7
Warranty	8

INSTALLATION

S Series air handlers are suitable for free-air return when enclosed in a closet with a louvered door or flush mounted in a wall.

Closet or "On the Wall" Applications

Note: If mounted in a closet a louver or grill with at least 1 square foot of face area per cooling ton is required on the door.

A wall hanging bracket is available as an accessory for this type of mounting. Attach bracket to wall so the "open" end faces up, make sure bracket is level and attached to the studs (2" x 8" blocking installed between studs at bracket height is recommended). 2" screws are required. Lift unit and slide the back edge of the top cap onto bracket.

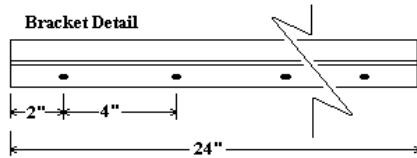
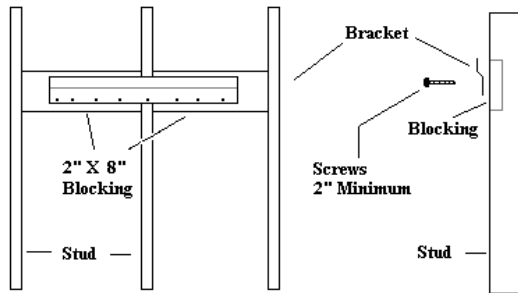

Bracket For "ON" The Wall Installations

Flush Mount or "In the Wall" Applications

Recess air handler 2" to provide adequate space for drain line connections. If a flush application is desired, a notch will need to be cut in the stud to allow for primary drain access. Do not allow the air handler to protrude beyond the front of the stud, this will interfere with the louvered wall

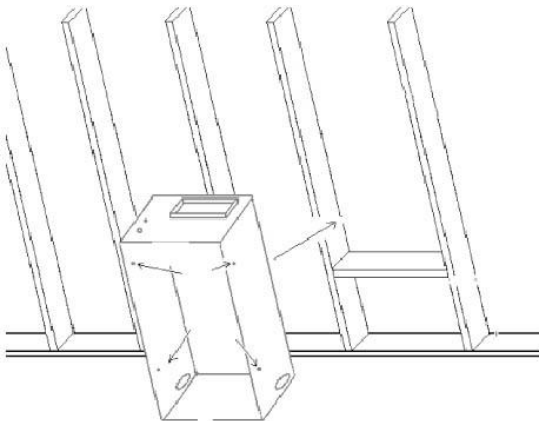

grille application. Use the 2 holes on each side to attach between studs. Make sure air handler is level and square before proceeding.

DUCTWORK

Ductwork should be fabricated and installed in accordance with local and/or national codes. This includes the standards of the National Fire Protection Association for installation of Air-Conditioning and Ventilating Systems, NFPA No. 90B.

CONDENSATE DRAIN

Determine the drain connections to be used and note the difference between the primary and secondary openings. Remove plugs from selected drain openings. It is recommended that 3/4" male pipe thread PVC fittings be used at the condensate pan. Hand tighten.

Tubing for all condensate drains should be a minimum of 7/8" OD. The drain should be pitched downward 1" per 10'. Install a 3" trap as close to the coil as possible.

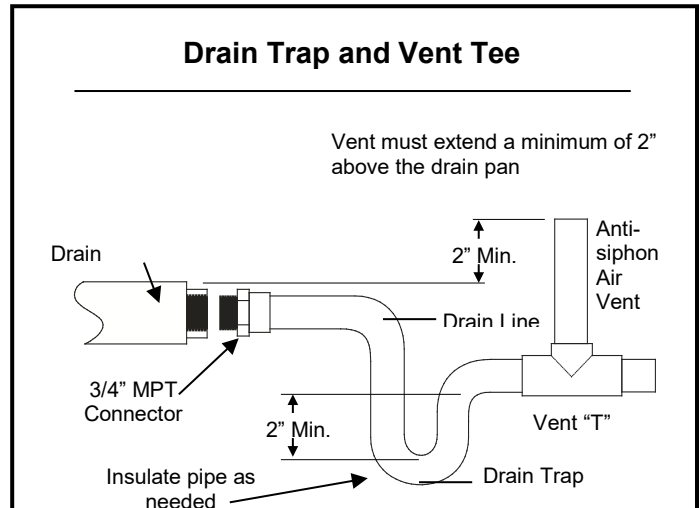

Route drain line so that it does not interfere with accessibility to the coil, air handling system or filter and will not be exposed to freezing temperatures.

If line makes a second trap, or has an extended run before termination, a vent tee should be installed after the trap closest to the pan. Connect the primary drain and route to an open drain, sump, or sewer line.

CAUTION

If the coil is located in or above a living space where damage may result from condensate overflow, a separate 3/4" drain must be provided from the secondary drain connection (or a Float Switch can be used - refer to kit instructions for installation procedures). Run this drain to a place in compliance with local installation codes where it will be noticed when unit is operational. Condensate flowing from the secondary drain indicates a plugged primary drain.

Prime the trap with water. Test line for leaks. Verify water flow with unit in operation.

WIRING

WARNING!

Use Copper Conductors Only

DANGER!

Electric shock hazard. Can cause injury or death. Before attempting to perform any service or maintenance, turn the electrical power to the unit OFF at disconnect switch(es). Unit may have multiple power supplies.

WARNING!

Run 24V Class 11 wiring only through the specified low voltage opening. Run the line voltage wiring only through the specified high voltage opening. Do not combine Voltage in one opening.

Wiring must conform to the current National Electric Code ANSI/NFPA No. 70, or Canadian Electric Code Part 1, CSA Standard C22.1, and local electric codes. See the unit nameplate for minimum circuit ampacity and maximum overcurrent protection size.

Select the proper supply circuit conductors according to tables 310-16 and 310-17 in the National Electric Code, ANSI/NFPA NO. 70 or Tables 1—4 in the Canadian Electric Code, Part 1, CSA Standard C22.1.

REFRIGERANT PIPING

Refrigerant connections are 3/8" ODF Liquid and 3/4" ODF Suction. Refer to outdoor unit manufacturer's recommendation on line sizing.

During brazing of refrigerant lines place a wet rag around suction line on top of cabinet to protect cabinet from overheating. Maintain a minimum of 1.5" from cabinet and refrigerant brazing connections.

REFRIGERANT FLOW CONTROLS

Refer to nomenclature to determine type of flow control installed and needed for your application. Evaporator coils are shipped from the factory with floriator pistons or TXV assemblies. Floriator pistons and TXV kits are available for field conversion.

PISTONS

As shipped from the factory, the piston installed in each coil is chosen for the nominal BTUH capacity of the coil. Verify with the condenser recommendation that proper floriator piston is selected.

When changing pistons use the following procedure:

1. Loosen hex nut located on liquid line and separate from distributor assembly.
2. Remove the existing piston from inside the distributor assembly
3. Insert the desired piston into the distributor assembly.
4. Inspect "O" ring and replace if damaged. Ensure gasket is in place.
5. Re-install hex nut to body and torque to 10 ft-lbs.

THERMAL EXPANSION VALVES

As shipped from the factory, the TXV installed in each coil is chosen for the nominal BTUH capacity of the coil. Attach and insulate the TXV bulb outside of the cabinet to the main suction line no more than one foot from the suction line connection.

Field installed TXV kits are also available. Refer to engineering guide or price sheet for sizes, and kit instructions for installation procedures.

REFRIGERANT LINE INSTALLATION

ADP recommends installing a filter drier and sight glass in the liquid line. While brazing, purge the system with Nitrogen to prevent contamination. ADP recommends reattaching and insulating the TXV sensing bulb at a 10 to 2 o'clock position on the suction line, outside the coil housing, no more than one foot from the connection. Evacuate the system to 500 microns to ensure proper air and moisture removal (**Note: Deep evacuation or triple evacuation method recommended**). Open the suction service valve slowly and allow the refrigerant to bleed into the system before opening the liquid service valve.

REFRIGERANT CHARGING INSTRUCTIONS

When charging in cooling mode, the outdoor temperature should be 60°F or higher. To allow the pressures to stabilize, operate the system a minimum of 15 minutes between adjustments. When adjusting charge to systems with micro-channel outdoor coils, make small (1 ounce or less) adjustments as these systems are very sensitive to refrigerant charge.

TXV Charging^{2, 3, 4} – Use the charging method recommended by the outdoor unit instructions. Alternatively, ADP recommends charging to 12°F sub-cooling for AC units and 10°F sub-cooling for heat pump units. In addition, if equipped with an adjustable valve, adjust to 10°F superheat.

Fixed Orifice Charging^{2, 3, 4} – Use the superheat recommended by the outdoor unit instructions. Alternatively, ADP recommends charging to the superheat table below.

Outdoor Air Temp. (°F)	60	65	70	75	80	85	90	95	100	105	110	115
Superheat (°F)	31	28	25	22	20	16	13	10	8	6	5	5

For heat pump units initially charged in the cooling mode, final adjustments to charge in the heating mode are acceptable if necessary. Some HP units require charging in the heating mode. In this case, refer to the outdoor instructions for recommended charging procedures.

If the system is undercharged after the initial charge, add refrigerant until the sight glass is clear and recommended pressures, temperatures, sub-cooling and superheat can

be obtained. If the system is overcharged after the initial charge, recover refrigerant until recommended pressures, temperatures, sub-cooling and superheat can be obtained.

Notes:

1. If any problems or questions regarding charge occur, contact customer service.
2. OEM charging methods vary depending on design and application. Verify all recommended pressures, temperatures, sub-cooling and superheat settings result in the proper charge.
3. ADP coils may require charge compensation due to size variation versus the OEM coil.
4. Temperatures are $\pm 2^{\circ}\text{F}$ unless otherwise recommended.

BLOWER SPEED CHANGES

To change motor speed settings remove motor wire from control board and replace with desired speed. See Airflow Data Table below for airflow performance.

AIR HANDLER MAINTENANCE

Caution

At the beginning of each heating or cooling season the unit should be serviced by a qualified installer or servicing agency.

If necessary to access the Air Handler blower motor for replacement, follow these steps:

1. Ensure all power is shut off to the unit
2. Remove the (4) 1/4" screws located on each side of the coil (two per side).
3. Remove the (2) 1/2" screws in the top plate on the coil and set the top cap to the side.
4. Gently pick the coil up out of the drain pan and slowly rotate the coil toward you. Ensure that the copper flex tube is bending in the middle and not kinking (see figure at right).
5. Stabilize the raised coil while servicing the motor.
6. Reverse the steps above to put the coil back into place.

Note: The copper flex tube is only made to bend 4 to 6 times over the life of the product.



AIRFLOW DATA

3-Speed PSC Motor

Unit Size	Cooling Speed Setting	Airflow (CFM) vs. External Static Pressure (inches W.C.) ***				
		0.1	0.2	0.3	0.4	0.5
18	* ^ Low - Red	606	591	576	559	529
	Med - Blue	802	784	751	722	693
	High -Black	1046	1013	987	943	885
24	Low - Red	606	591	576	559	529
	* ^ Med - Blue	802	784	751	722	693
	High -Black	1046	1013	987	943	885
30	Low - Red	816	809	802	775	752
	* ^ Med - Blue	1000	985	970	935	889
	High -Black	1218	1175	1122	1070	1008
36	Low - Red	816	809	802	775	752
	Med - Blue	1000	985	970	935	889
	* ^ High -Black	1218	1175	1122	1070	1008

* Factory setting for cooling.

^ Factory setting for heating.

*** All airflow data is with a dry coil, filter, & electric heat.

5-Speed High Efficiency ECM Motor

Unit Size	Cooling Speed Setting	Airflow (CFM) vs. External Static Pressure (inches W.C.) ***				
		0.1	0.2	0.3	0.4	0.5
19	Tap 1	547	484	366	309	268
	* Tap 2	651	600	566	516	466
	Tap 3	695	646	617	566	544
	^ Tap 4	742	700	669	627	600
	Tap 5	758	712	682	641	625
25	Tap 1	569	453	347	264	264
	Tap 2	659	600	569	518	475
	* Tap 3	847	800	787	744	722
	^ Tap 4	928	901	883	846	802
	Tap 5	970	944	927	891	864
31	Tap 1	656	600	567	522	473
	Tap 2	842	800	782	739	716
	* Tap 3	1059	1028	1004	972	946
	^ Tap 4	1106	1084	1053	1030	1000
	Tap 5	1137	1108	1085	1055	1031
37	Tap 1	848	800	769	726	692
	Tap 2	1051	1028	1000	956	930
	* Tap 3	1247	1215	1188	1161	1126
	^ Tap 4	1310	1279	1254	1228	1200
	Tap 5	1364	1334	1304	1279	1250
39	Tap 1	800	783	747	725	689
	Tap 2	1034	1003	987	959	937
	* Tap 3	1281	1253	1228	1207	1186
	^ Tap 4	1343	1314	1290	1261	1226
	Tap 5	1367	1342	1312	1277	1239

* Factory setting for cooling.

^ Factory setting for heating.

*** All airflow data is with a dry coil, filter, & electric heat.

Electrical Data

3-Speed PSC Motor

Unit Size (All have electric heat)	Heating Capacity		Blower Amps		Minimum Circuit Ampacity		Circuit Breaker Amps Per Stage	
	kW	BTUH						
	240 V ^[1]	240 V ^[1]	208 V	240 V	208 V	240 V	208 V	240 V
18	5.0	17,065	1.8	1.7	24.8	28.2	30	30
	7.5	25,598	1.8	1.7	36.1	41.2	40	45
	10.0	34,130	1.8	1.7	47.4	54.2	50	60
24	5.0	17,065	1.8	1.7	24.8	28.2	30	30
	7.5	25,598	1.8	1.7	36.1	41.2	40	45
	10.0	34,130	1.8	1.7	47.4	54.2	50	60
30	5.0	17,065	2.1	2.0	25.2	28.5	30	30
	7.5	25,598	2.1	2.0	36.5	41.6	40	45
	10.0	34,130	2.1	2.0	47.8	54.6	50	60
36	5.0	17,065	2.1	2.0	25.2	28.5	30	30
	7.5	25,598	2.1	2.0	36.5	41.6	40	45
	10.0	34,130	2.1	2.0	47.8	54.6	50	60

[1] For 208 Volts use .751 correction factor for kW & MBTUH.

5-Speed High Efficiency ECM Motor

Unit Size (All have electric heat)	Heating Capacity		Blower Amps		Minimum Circuit Ampacity		Circuit Breaker Amps Per Stage	
	kW	BTUH						
	240 V ^[1]	240 V ^[1]	208 V	240 V	208 V	240 V	208 V	240 V
19	5.0	17,065	0.9	0.8	23.7	27.0	30	30
	7.5	25,598	0.9	0.8	35.0	40.1	40	45
	10.0	34,130	0.9	0.8	46.3	53.1	50	60
25	5.0	17,065	1.8	1.7	24.8	28.2	30	30
	7.5	25,598	1.8	1.7	36.1	41.2	40	45
	10.0	34,130	1.8	1.7	47.4	54.2	50	60
31	5.0	17,065	2.4	2.2	25.6	28.8	30	30
	7.5	25,598	2.4	2.2	36.8	41.8	40	45
	10.0	34,130	2.4	2.2	48.1	54.8	50	60
37	5.0	17,065	3.1	2.9	26.4	29.7	30	30
	7.5	25,598	3.1	2.9	37.7	42.7	40	45
	10.0	34,130	3.1	2.9	49.0	55.7	50	60
39	5.0	17,065	3.1	2.9	26.4	29.7	30	30
	7.5	25,598	3.1	2.9	37.7	42.7	40	45
	10.0	34,130	3.1	2.9	49.0	55.7	50	60

[1] For 208 Volts use .751 correction factor for kW & MBTUH.

ASSISTANCE OR SERVICE

If you need further assistance, you may visit our website or e-mail us with any questions or concerns. Please include a daytime phone number in your correspondence.

Website: www.adpnow.com

LOW VOLTAGE THERMOSTAT CONNECTIONS – 3-SPEED MOTOR

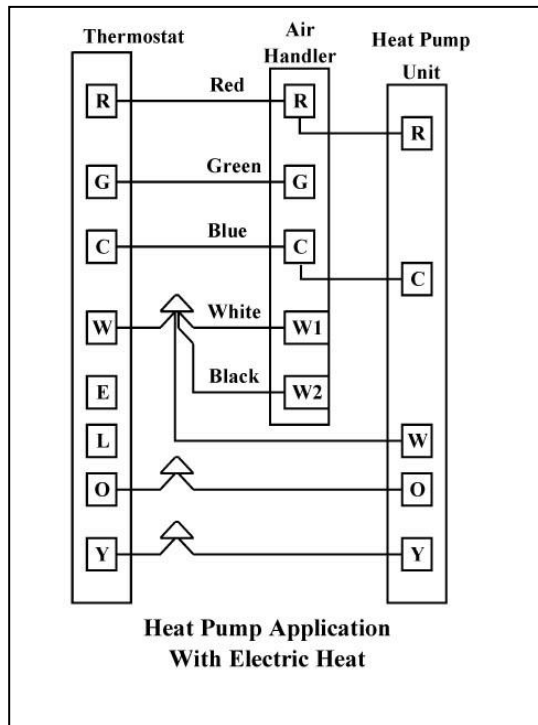
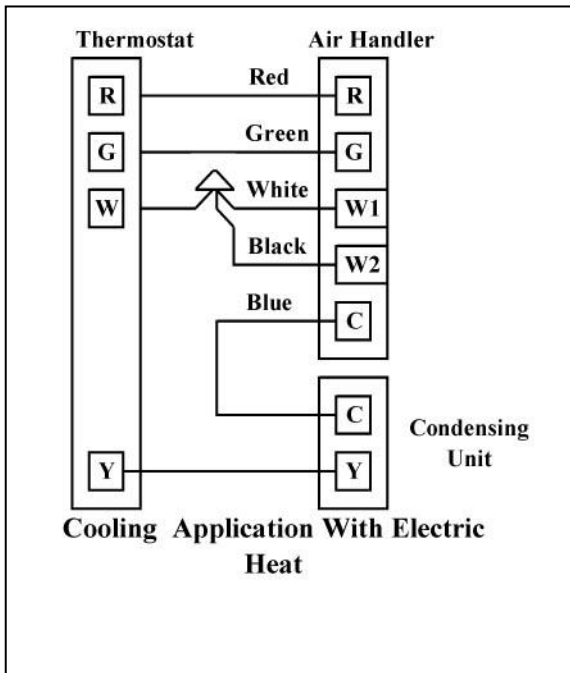

LOW VOLTAGE THERMOSTAT CONNECTIONS – 5-SPEED HIGH EFFICIENCY ECM MOTOR

For high static system, identify desired tap/CFM and jumper "Y1" & "DS" at air handler terminal block.
 For 2 stage outdoor units:

- Identify desired tap/CFM for 1st stage from airflow chart and move motor lead on terminal board to Y1.
- Identify desired tap/CFM for 2nd stage from airflow chart and move motor lead on terminal board to Y2.

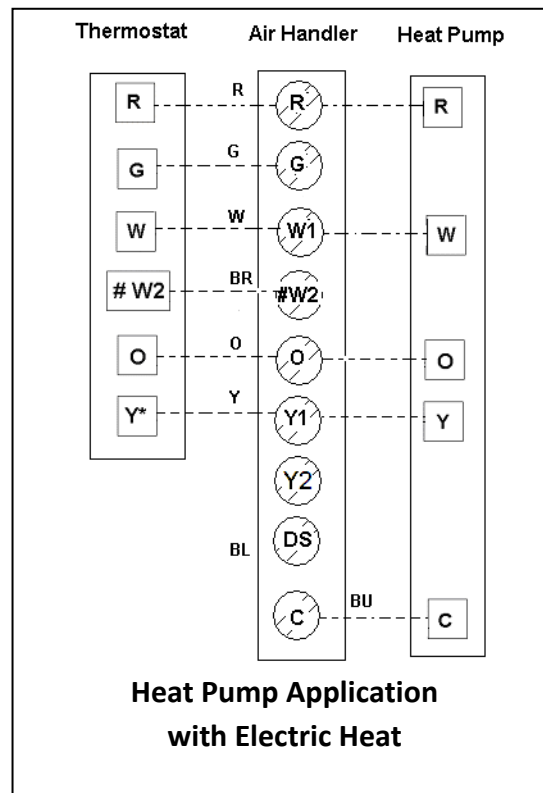
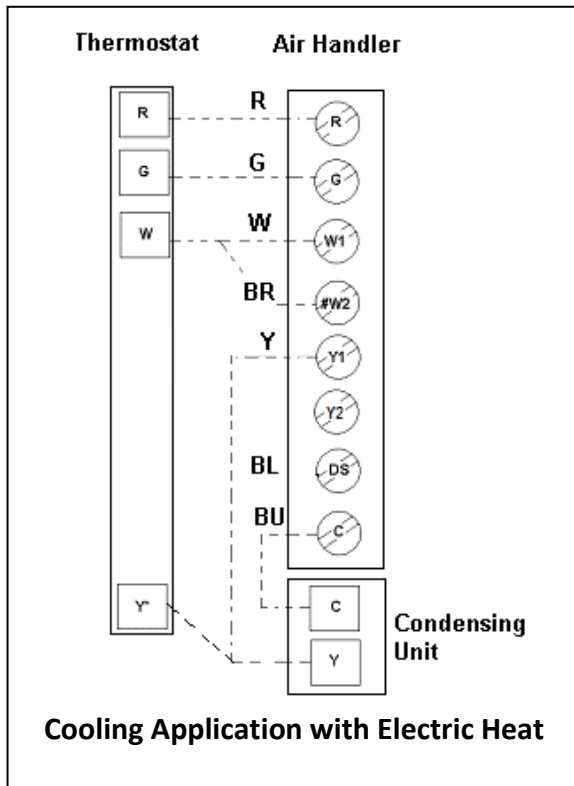

WIRING DIAGRAM - 3-SPEED MOTOR

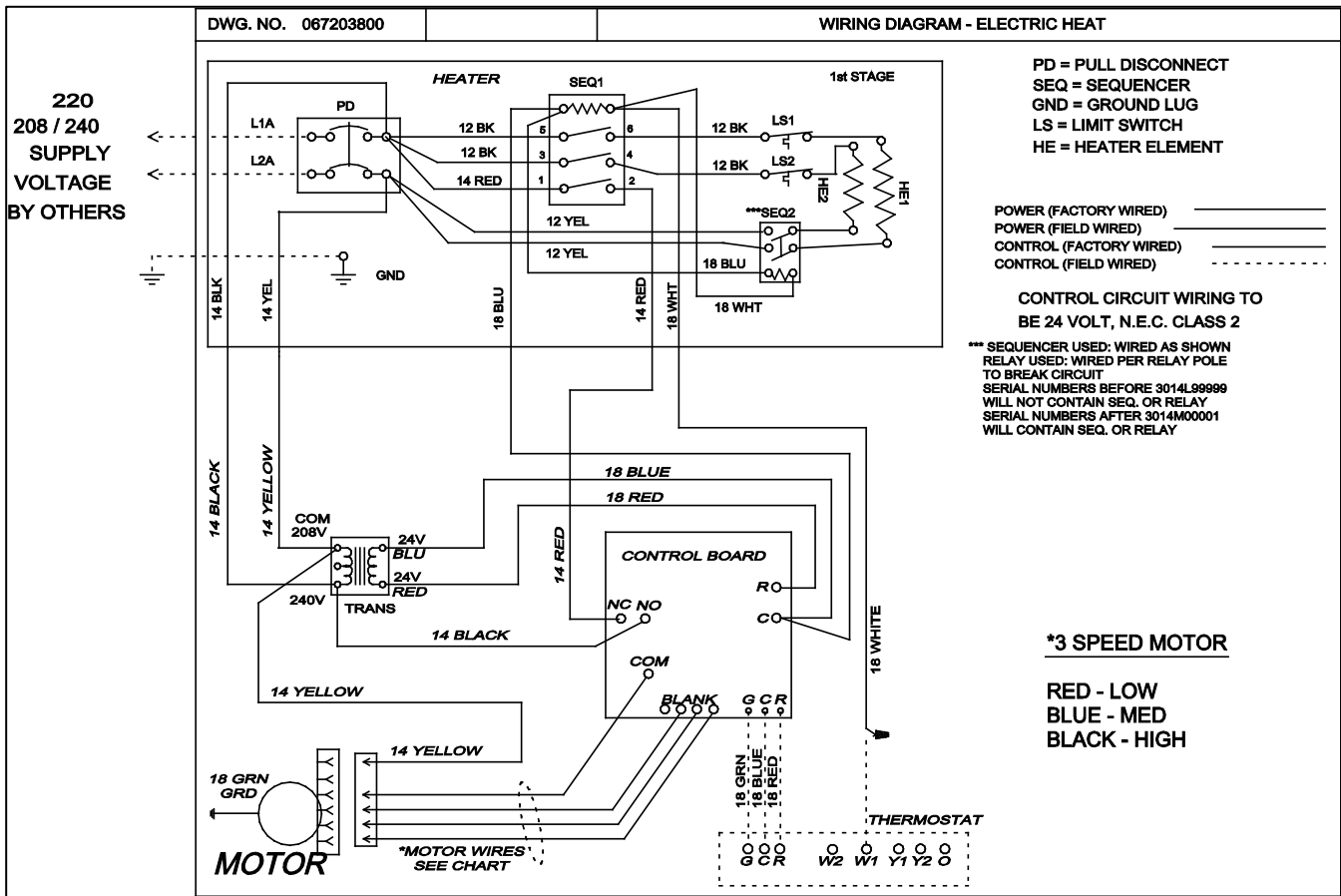

WIRING DIAGRAM - 5-SPEED MOTOR HIGH EFFICIENCY ECM MOTOR

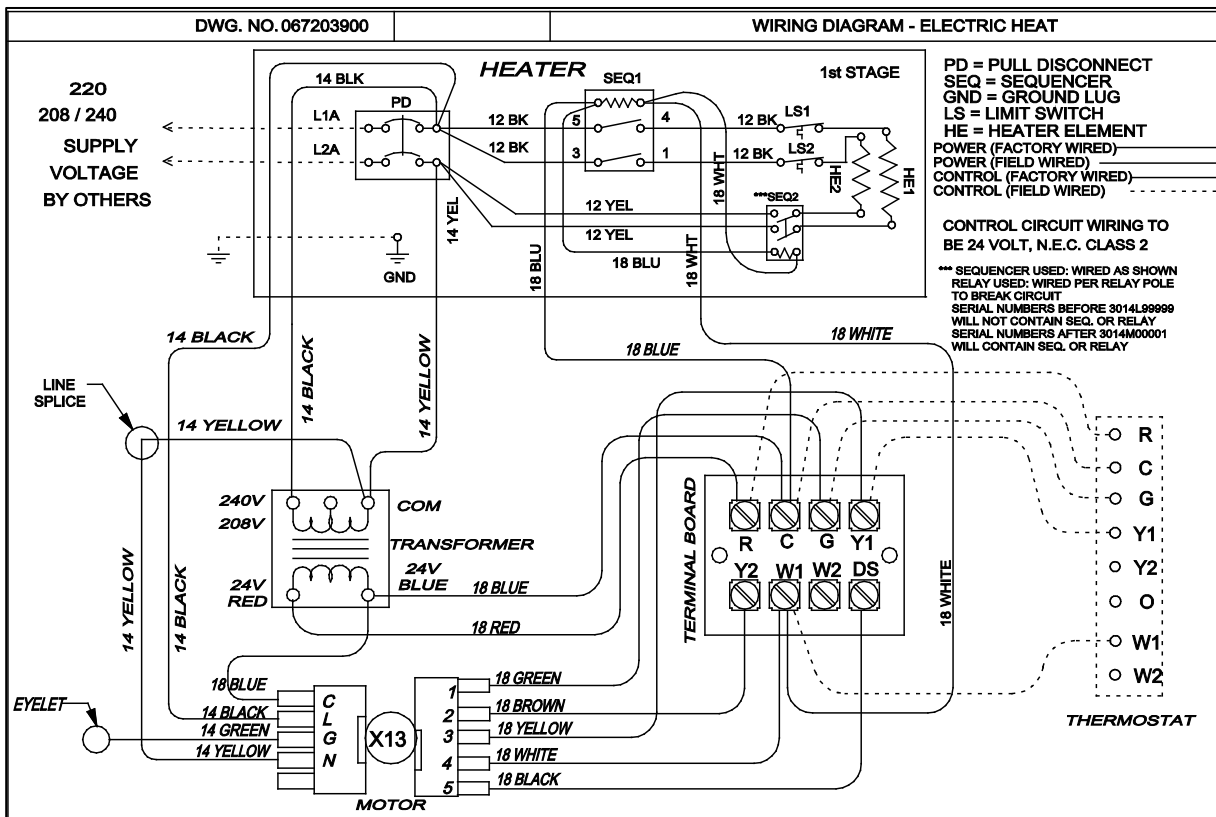

ADP Air Handler Limited Warranty

Term of Warranty: Advanced Distributor Products (ADP) warrants that products sold shall be of merchantable quality, free of defects in material and workmanship, under normal use and service, for a period of five (5) years from the date of installation, not to exceed six (6) years from the date of manufacture subject to the terms of ADP's limited warranty.

For information on this product's warranty, including accessing complete warranty terms, registering for an extended warranty*, or obtaining instructions on filing a warranty claim, please go to www.ADPwarranty.com.

* In such states or provinces where registration requirements are prohibited, failure to complete registration by the consumer does not diminish his or her warranty rights.

EQUIPMENT INFORMATION

Please complete information below and retain this warranty for records and future reference.

Unit Model Number: _____

Serial Number: _____

Installing Contractor: _____

Installation Date: _____ Phone: _____

