

Specification Guide

S Series Compact Wall Mount Air Handlers Electric Heat

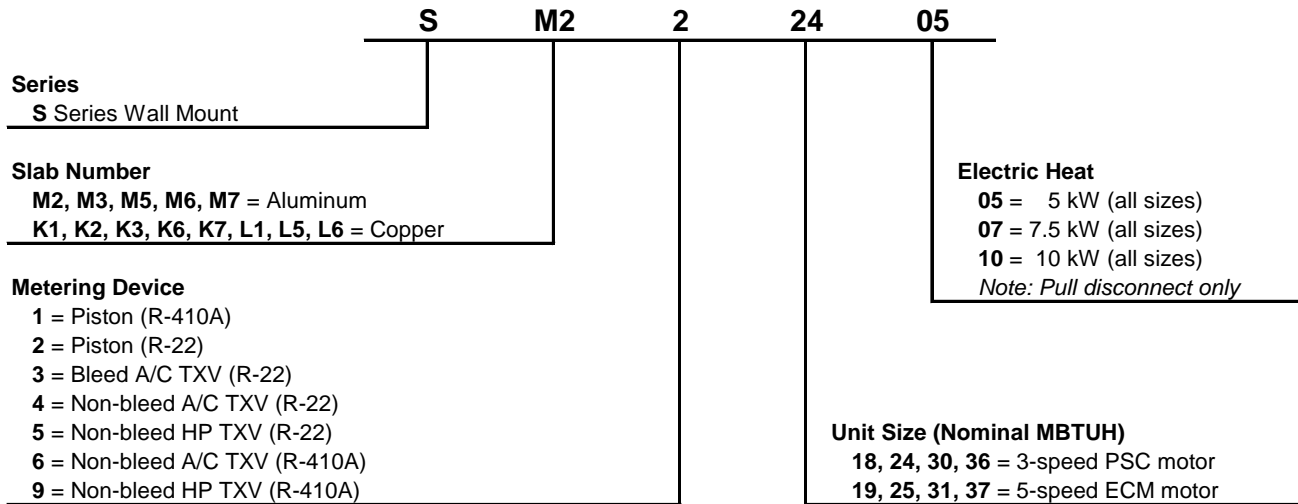

Contents	Page
Nomenclature.....	1
Product Features	2
Physical Data	2
Blower Performance.....	3
Dimensions	3
Electrical Data.....	4



Product improvement is a continuous process at Advanced Distributor Products. Therefore, product specifications are subject to change without notice and without obligation on our part. Please contact your ADP representative or distributor to verify details.
© by Advanced Distributor Products. All rights reserved.

Product Features

Cabinet & General Features

- Patent pending flexible copper tubing for easy motor access.
- Low 30" height all models, all sizes.
- Cabinets constructed of heavy-gauge, corrosion-resistant galvanized steel.
- Refrigerant connections located on top left.
- 5/8" foil-faced insulation for excellent sweat resistance and quiet operation.
- (4) Screw removal for easy access to all electrical connections.
- Dual condensate drain connections on left side, right side, and bottom of cabinet.
- 1" duct flanges on all models simplify attachment to plenums such as 1 1/2" ductboard.
- Air filter included with every air handler; no tools required for changeout.
- Decorative wall panel (26"w x 38"h) or closet panel (24"w x 27"h) available as accessory; both panels reduce published sound level.
- Wall hanging bracket available as accessory for field installation.
- Approved for installation in manufactured housing and mobile homes.

Coil Features

- AC or HP applications; R-22 & R-410A compatible.
- Light weight aluminum evaporator coil with aluminum header plate; copper coil available.
- Field or factory installed threaded expansion valve.
- Corrosion proof plastic drain pan.

Electrical Features

- 5-speed high efficiency ECM motor or PSC motor available.
- Easy to service electric heat section.
- 5, 7.5, or 10 kW heat kits standard factory installed on all models.
- Pull disconnect line voltage connection standard on all models.
- Patented condensate drain pan safety float switch available as accessory.
- Includes thermostat connections, time delay (1 sec. on, 45 sec. off), & motor speed settings (PSC motor uses control board; functions are built into the 5-speed ECM motor).

Physical Data

	Unit Size								
	18	19	24	25	30	31	36	37	
Available Voltages	208/240 V, 60 Hz, 1 Phase								
Maximum Elec. Heat available (kW)	10	10	10	10	10	10	10	10	
Transformer Size and Type	40VA, Class 2								
Blower Data: 3-Speed PSC Motor	Motor H.P.	1/4	--	1/4	--	1/3	--	1/3	--
	F.L.A. @ 240 V	1.7	--	1.7	--	2.0	--	2.0	--
Blower Data: 5-Speed High Eff. ECM Motor	Motor H.P.	--	1/3	--	1/3	--	1/3	--	1/2
	F.L.A. @ 240 V	--	0.8	--	1.7	--	2.2	--	2.9
Wheel (dia." x width")	10 x 6	10 x 6	10 x 6	10 x 6	10 x 6	10 x 6	10 x 6	10 x 6	
Nominal CFM	600	600	800	800	1000	1000	1200	1200	
Air Filter Size (in)	20 x 20	20 x 20	20 x 20	20 x 20	20 x 20	20 x 20	20 x 25	20 x 25	
Refrigerant Conn. (IDS) Suction	3/4"	3/4"	3/4"	3/4"	3/4"	3/4"	3/4"	3/4"	
Refrigerant Conn. (IDS) Liquid	3/8"	3/8"	3/8"	3/8"	3/8"	3/8"	3/8"	3/8"	
R-410A Piston Size (in)	0.049	0.049	0.053	0.053	0.059	0.059	0.067	0.067	
R-22 Piston Size (in)	0.053	0.053	0.059	0.059	0.067	0.067	0.073	0.073	
Pallet Quantity (min order per model number)	4	4	4	4	4	4	4	4	
Sound Level @ 0.3 Static w/o Wall Panel (dB)	60	60	64	64	69	69	72	69	
Copper Weights									
Max Unit Weight (lbs)	78	81	78	81	81	84	81	84	
Max Shipping Weight (lbs)	85	90	85	90	90	95	100	105	
Aluminum Weights									
Max Unit Weight (lbs)	73	76	73	76	76	79	76	79	
Max Shipping Weight (lbs)	80	85	80	85	85	90	95	100	

Note: 18" clearance required in front of unit for filter and coil maintenance. Can be less if front panel is directly behind a louvered closet door; check local codes and regulations.

Note: Minimum order quantity of 4 per model number.

Blower Performance

- Heating speeds should not be reduced below factory setting.
- Different speeds can be set for cooling mode; see installation instructions.

3-Speed PSC Motor

Unit Size	Cooling Speed Setting	Airflow (CFM) vs. External Static Pressure (inches W.C.) ***				
		0.1	0.2	0.3	0.4	0.5
18	* ^ Low - Red	606	591	576	559	529
	Med - Blue	802	784	751	722	693
	High -Black	1046	1013	987	943	885
24	Low - Red	606	591	576	559	529
	* ^ Med - Blue	802	784	751	722	693
	High -Black	1046	1013	987	943	885
30	Low - Red	816	809	802	775	752
	* ^ Med - Blue	1000	985	970	935	889
	High -Black	1218	1175	1122	1070	1008
36	Low - Red	816	809	802	775	752
	Med - Blue	1000	985	970	935	889
	* ^ High -Black	1218	1175	1122	1070	1008

* Factory setting for cooling.

^ Factory setting for heating.

*** All airflow data is with a dry coil, filter, & electric heat.

5-Speed High Efficiency ECM Motor

Unit Size	Cooling Speed Setting	Airflow (CFM) vs. External Static Pressure (inches W.C.) ***				
		0.1	0.2	0.3	0.4	0.5
19	Tap 1	547	484	366	309	268
	* Tap 2	651	600	566	516	466
	Tap 3	695	646	617	566	544
	^ Tap 4	742	700	669	627	600
	Tap 5	758	712	682	641	625
25	Tap 1	569	453	347	264	264
	Tap 2	659	600	569	518	475
	* Tap 3	847	800	787	744	722
	^ Tap 4	928	901	883	846	802
	Tap 5	970	944	927	891	864
31	Tap 1	656	600	567	522	473
	Tap 2	842	800	782	739	716
	* Tap 3	1059	1028	1004	972	946
	^ Tap 4	1106	1084	1053	1030	1000
	Tap 5	1137	1108	1085	1055	1031
37	Tap 1	848	800	769	726	692
	Tap 2	1051	1028	1000	956	930
	* Tap 3	1247	1215	1188	1161	1126
	^ Tap 4	1310	1279	1254	1228	1200
	Tap 5	1364	1334	1304	1279	1250

* Factory setting for cooling.

^ Factory setting for heating.

*** All airflow data is with a dry coil, filter, & electric heat.

Dimensions

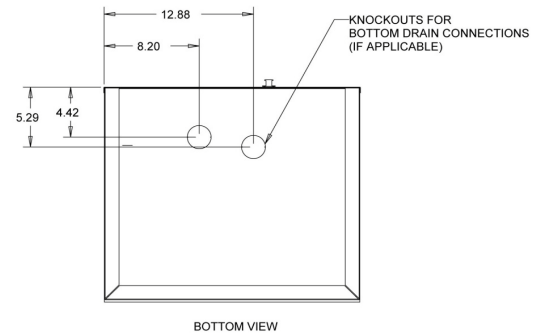
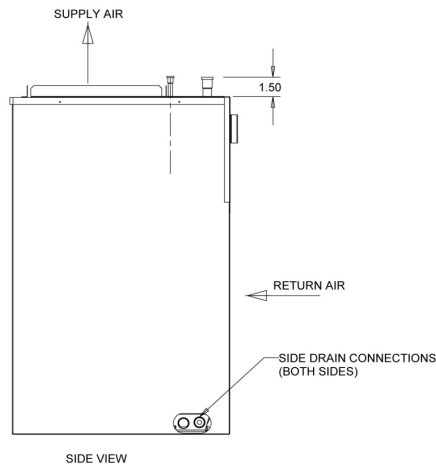
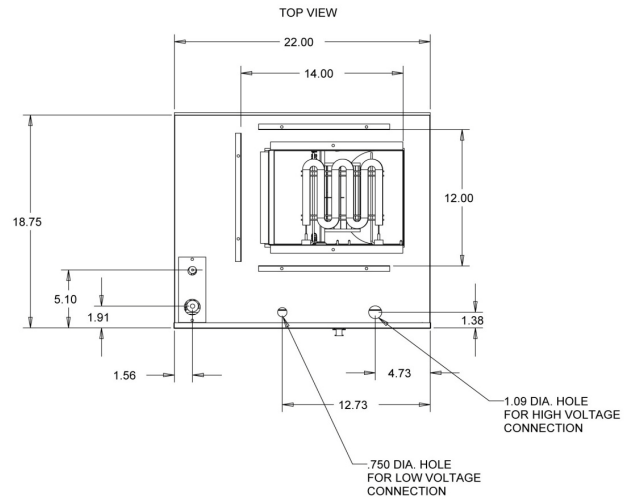
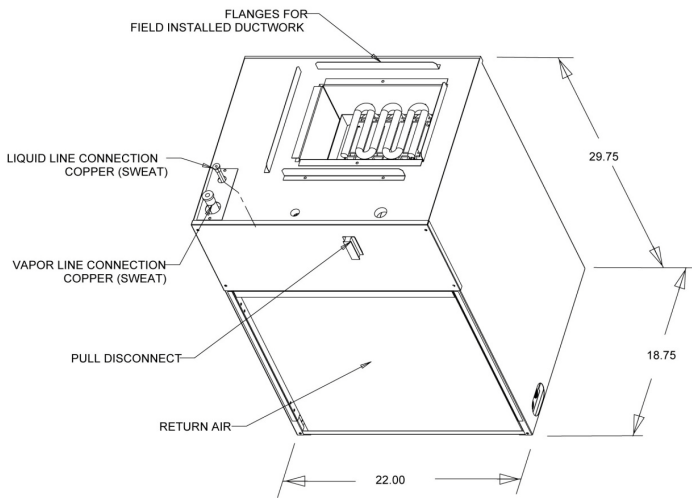

Electrical Data

3-Speed PSC Motor

Unit Size (All have electric heat)	Heating Capacity		Blower Amps		Minimum Circuit Ampacity		Circuit Breaker Amps Per Stage
	kW	BTUH	208 V	240 V	208 V	240 V	
	240 V ^[1]	240 V ^[1]					
18	5.0	17,065	1.8	1.7	24.8	28.2	30
	7.5	25,598	1.8	1.7	36.1	41.2	45
	10.0	34,130	1.8	1.7	47.4	54.2	60
24	5.0	17,065	1.8	1.7	24.8	28.2	30
	7.5	25,598	1.8	1.7	36.1	41.2	45
	10.0	34,130	1.8	1.7	47.4	54.2	60
30	5.0	17,065	2.1	2.0	25.2	28.5	30
	7.5	25,598	2.1	2.0	36.5	41.6	45
	10.0	34,130	2.1	2.0	47.8	54.6	60
36	5.0	17,065	2.1	2.0	25.2	28.5	30
	7.5	25,598	2.1	2.0	36.5	41.6	45
	10.0	34,130	2.1	2.0	47.8	54.6	60

[1] For 208 Volts use .751 correction factor for kW & MBTUH.

5-Speed High Efficiency ECM Motor

Unit Size (All have electric heat)	Heating Capacity		Blower Amps		Minimum Circuit Ampacity		Circuit Breaker Amps Per Stage
	kW	BTUH	208 V	240 V	208 V	240 V	
	240 V ^[1]	240 V ^[1]					
19	5.0	17,065	0.9	0.8	23.7	27.0	30
	7.5	25,598	0.9	0.8	35.0	40.1	45
	10.0	34,130	0.9	0.8	46.3	53.1	60
25	5.0	17,065	1.8	1.7	24.8	28.2	30
	7.5	25,598	1.8	1.7	36.1	41.2	45
	10.0	34,130	1.8	1.7	47.4	54.2	60
31	5.0	17,065	2.4	2.2	25.6	28.8	30
	7.5	25,598	2.4	2.2	36.8	41.8	45
	10.0	34,130	2.4	2.2	48.1	54.8	60
37	5.0	17,065	3.1	2.9	26.4	29.7	30
	7.5	25,598	3.1	2.9	37.7	42.7	45
	10.0	34,130	3.1	2.9	49.0	55.7	60

[1] For 208 Volts use .751 correction factor for kW & MBTUH.