

W SERIES AIR HANDLER

WALL MOUNT INSTALLATION INSTRUCTIONS



WARNING!

Product contains fiberglass wool. Disturbing the insulation in this product during installation, maintenance or repair will expose you to fiberglass wool. This material may cause respiratory, skin, and eye irritant. Breathing this may cause lung cancer. (Fiberglass wool is known to the State of California to cause cancer.)

RECEIVING

Check equipment for shipping damage. If you find any damage, immediately contact the last carrier. Check the unit rating plate for unit size, electric heat, coil, voltage, phase etc. to be sure unit matches requirements.

GENERAL

These instructions are intended as a general guide and do not supersede local codes in any way. Consult with authorities having jurisdiction before installation. ADP "W" series air handlers are suitable for closet or flush mount installations and are designed for electrical heat installation with a matched remote outdoor unit. These units are designed for indoor installations only.

IMPORTANT

The Clean Air Act of 1990 bans the intentional venting of refrigerant (CFC's and HFC's) as of July 1, 1992. Approved methods of reclaiming must be followed. Fines and/or incarceration may be levied for non-compliance.

REQUIREMENTS

Installation of air handler units with or without optional electric heat must conform with standards in the National Fire Protection Association (NFPA) "Standard for installation of Air Conditioning and Ventilation Systems NFPA No. 90A," and Standard for Installation of Residence Type warm Air Heating and Air Conditioning Systems NFPA No. 90B, manufacturer's installation instructions and local municipal building codes.

This unit is certified for installation clearances to combustible material as listed on the unit rating plate. Accessibility and service clearances must take precedence over combustible material clearances.

The following words are used throughout this manual to identify levels of hazard seriousness.

DANGER-Immediate hazards that WILL result in severe personal injury or death.

WARNING-Hazards or unsafe practices COULD result in severe personal injury or death.

CAUTION-Hazards or unsafe practices COULD result in minor personal injury or product or property damage.

TABLE OF CONTENTS

Condensate Drain	3
Refrigerant Charging Instructions	3
Wiring Low Voltage Connections	5
Physical Data, Nomenclature	6-7
Electrical Wiring Diagram	9
Dimensions	10

INSTALLATION

W Series air handlers are suitable for free-air return as enclosed in a closet with a louvered door, flush mounted in a wall, or typical upflow application with bottom return air duct.

Closet or "ON" the wall applications

Note: If mounted in a closet a louver or grill with at least 1 square foot of face area per ton is required on the door.

A bracket is supplied for this type of mounting. Attach bracket to wall so the "open" end faces up, make sure bracket is level and attached to the studs (2" x 8" blocking installed between studs at bracket height is recommended). 2" screws are required. Remove the center screw that attaches the top cap to the back of the air handler. Lift unit and slide the back edge of the top cap onto bracket.

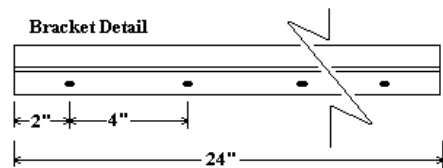
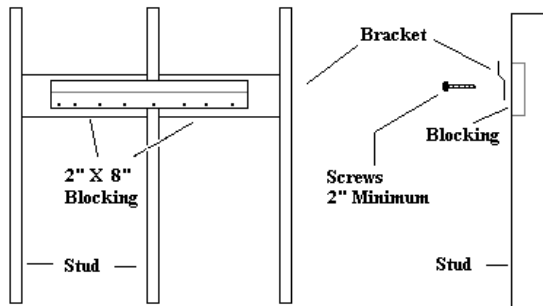

Bracket For "ON" The Wall Installations

Flush Mount or "IN" the wall applications

Maintain a 10" clearance from floor for condensate connections. Mount so air handler is flush with the front face of studs. Use the 2 holes on each side to attach between studs. Make sure air handler is level and square before proceeding. Attach brace in the upright position across the top of the unit (refer to drawing).

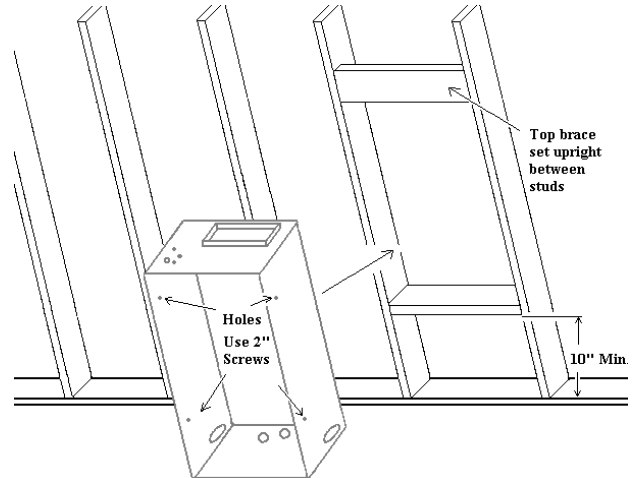

DUCTWORK

Ductwork should be fabricated and installed in accordance with local and/or national codes. This includes the standards of the National Fire Protection Association for installation of Air-Conditioning and Ventilating Systems, NFPA No. 90B.

REFRIGERANT PIPING

Refrigerant connections are 3/8" ODF Liquid and 3/4" ODF (18-36) or 7/8" ODF (42). Refer to outdoor unit manufacturer's recommendation on line sizing.

REFRIGERANT FLOW CONTROLS

Refer to nomenclature on page 5 to determine type of flow control installed. Evaporator coils are shipped from the factory with flator or TXV assemblies. Orifice and TXV kits are available for field conversion.

FLORATOR PISTONS

As shipped from the factory, the florator piston installed in each coil is chosen for the nominal BTUH capacity of the coil. A label on the liquid line identifies the piston size. For optimum performance, the piston should be sized to match the nominal BTUH of the condensing unit. Use the chart below for proper sizing.

Unit Size	ADP Piston Size
18	# 53
24	# 59
30/31	# 67
36	# 73
42	# 80

When changing pistons use the following procedure:

1. Loosen hex nut located on liquid line and separate from distributor assembly.
2. Remove the existing piston from inside the distributor assembly
3. Insert the desired ADP piston into the distributor assembly.
4. Inspect "O" ring and replace if damaged. Ensure gasket is in place.
5. Re-install floranor nut to body and torque to 10 ft-lbs.

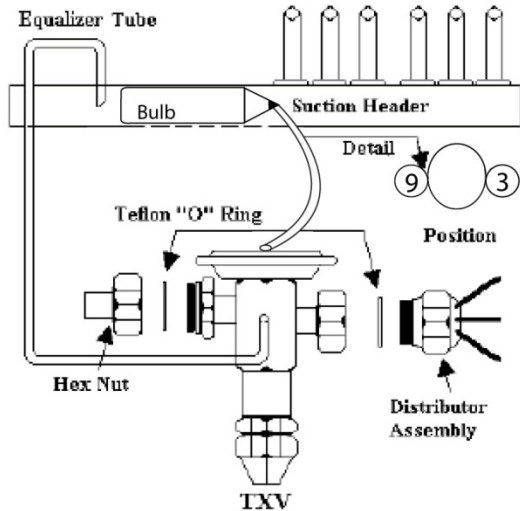

THERMAL EXPANSION VALVES

As shipped from the factory, the TXV installed in each coil is chosen for the nominal BTUH capacity of the coil.

If the sensing bulb on the TXV is removed during installation of the air handler be sure the bulb is relocated to the suction header as shown above. Wire ties or straps should be used to hold bulb in position. Cork tape or insulation wrapped around bulb will improve accuracy of mechanism.

Field installed TXV kits are also available. Refer to engineering guide or price sheet for sizes, and kit instructions for installation procedures.

REFRIGERANT CHARGING INSTRUCTIONS

Outdoor temperature should be 60°F or higher. Set the system to cooling mode and charge per the applicable method listed below. For Heat Pump units initially charged in cooling mode, final adjustment to charge in heating mode is acceptable if necessary. When charging Heat Pumps in the heating mode please refer to the outdoor unit's charging instructions.

FIXED ORIFICE 1. Run system for at least 10 minutes to allow pressure to stabilize. 2. Add or recover refrigerant until the superheat matches the table below.

Outdoor Air Temp. (°F)	Superheat (°F)		
	Min	Nom	Max
60	28	31	34
65	25	28	31
70	22	25	28
75	20	22	25
80	16	20	22
85	13	16	20
90	10	13	16
95	6	10	12
100	6	8	10
105	4	6	8
110	4	5	6
115	4	5	6

EXPANSION VALVE 1. Run system for at least 10 minutes to allow pressure to stabilize. 2. Add or recover refrigerant until the subcooling matches the table below. 3. If equipped, adjust the valve until the superheat matches the table below.

Subcooling (°F)			Superheat (°F)		
Min	Nom	Max	Min	Nom	Max
10	12	14	6	10	12

CONDENSATE DRAIN

CAUTION!

Unit is equipped with side and bottom openings. If bottom openings are not used- they must be plugged!

Determine the drain connections to be used and note the difference between the primary and secondary openings.

If side openings are used, use screwdriver to remove webbing from selected openings.

It is recommended that 3/4" male pipe thread PVC fittings be used at the condensate pan. **Do not over-tighten.**

Tubing for all condensate drains should be a minimum of 7/8" OD. The drain should be pitched downward 1" per 10'. Install a 3" trap as close to the coil as possible.

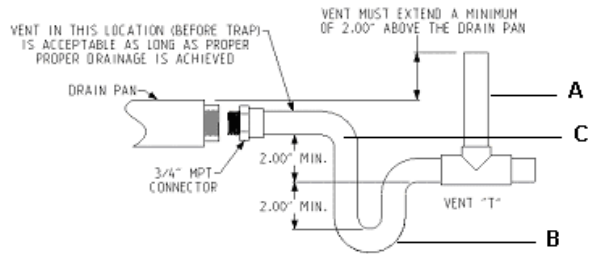

A. Anti-siphon air vent (for horizontal runs of 15 ft or longer)
B. Drain trap
C. Drain line

Route drain line so that it does not interfere with accessibility to the coil, air handling system or filter and will not be exposed to freezing temperatures.

If line makes a second trap, or has an extended run before termination, a vent tee should be installed after the trap closest to the pan. Connect the primary drain and route toward an open drain or sump.

If the coil is located in or above a living space where damage may result from condensate overflow, a separate 3/4" drain must be provided from the secondary drain connection (or a **Safety Float Switch, part # 65534000**, can be used - refer to kit instructions for installation procedures). Run this drain to a place in compliance with local installation codes where it will be noticed when unit is operational. Condensate flowing from the secondary drain indicates a plugged primary drain. Prime the trap with water. Test line for leaks. Test water flow with unit in operation.

WIRING

DANGER!

Electric shock hazard. Can cause injury or death. Before attempting to perform any service or maintenance, turn the electrical power to the unit OFF at disconnect switch(es). Unit may have multiple power supplies.

WARNING!

USE COPPER CONDUCTORS ONLY

WARNING!

Run 24V Class 11 wiring only through the specified low voltage opening. Run the line voltage wiring only through the specified high voltage opening. Do not combine Voltage in one opening.

Wiring must conform to the current National Electric Code ANSI/NFPA No. 70, or Canadian Electric Code Part 1, CSA Standard C22.1, and local electric codes. Refer to the following wiring diagrams. See the unit nameplate for minimum circuit ampacity and maximum overcurrent protection size.

Select the proper supply circuit conductors according to tables 310-16 and 310-17 in the National Electric Code, ANSI/NFPA NO. 70 or Tables 1 - 4 in the Canadian Electric Code, Part 1, CSA Standard C22.1.

If the air handler is purchased and installed with a heat kit and needs to be converted in the field back to no heat a "no heat reversion package" is required for operation. See ADP's Air Handler Accessories Sheet for further details.

BLOWER SPEED CHANGES

From the factory the blower is set on medium speed (blue). To change to high (black), or low (red), remove the (blue) wire from the number 2 port and replace it with the (black) or (red) wire depending on your desired speed setting.

Low Voltage Connections

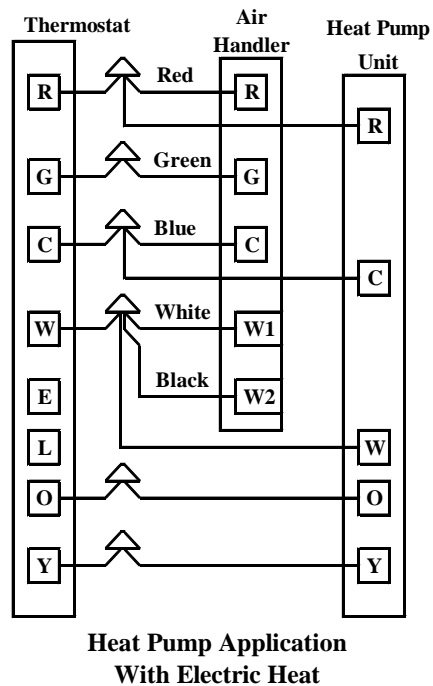
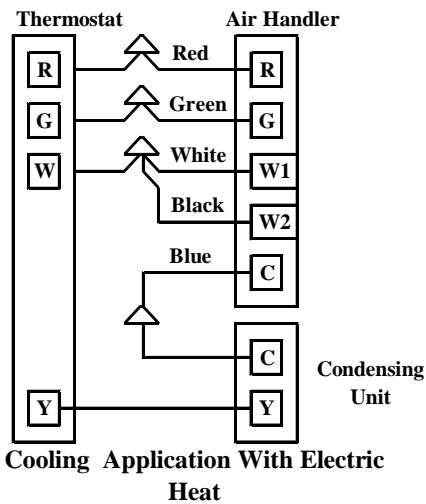
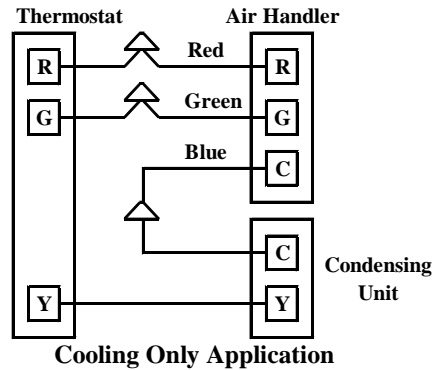

PHYSICAL DATA

		Model					
		18	24	30	31	36	42
Available Voltages		208/240 V, 60 Hz, 1 Phase					
Maximum Elec. Heat available (kW)		10	10	10	10	15	15
Transformer Size and Type		40VA, Class 2					
Blower Data	Wheel (dia." X width")	10 x 6	10 x 6	10 x 6	10 X 8	10 x 8	10 x 8
	Motor H.P.	1/5	¼	1/3	1/3	½	½
	F.L.A.@240 V	1.1	1.9	2.2	2.6	3.0	3.0
	Speed	3	3	3	3	3	3
	Nominal CFM	600	800	1000	1000	1200	1400
Air Filter Size		20" x 20"	20" x 20"	20" x 20"	20" x 25"	20" x 25"	20" x 25"
Refrigerant Conn.(IDS)Suction		¾"	¾"	¾"	¾"	¾"	7/8"
Refrigerant Conn. (IDS) Liquid		3/8"	3/8"	3/8"	3/8"	3/8"	3/8"
Florator Piston Size		53	59	67	67	73	80
Weights Approx. lbs.		99	101	103	118	118	121

AIR HANDLER MAINTENANCE

AT THE BEGINNING OF EACH HEATING SEASON THE UNIT SHOULD BE SERVICED BY A QUALIFIED INSTALLER OR SERVICING AGENCY.

ASSISTANCE OR SERVICE

IF YOU NEED FURTHER ASSISTANCE, YOU MAY CONTACT US AT THE ADDRESS BELOW OR E-MAIL US WITH ANY QUESTIONS OR CONCERNS. PLEASE INCLUDE A DAYTIME PHONE NUMBER IN YOUR CORRESPONDENCE.

ADVANCED DISTRIBUTOR PRODUCTS
 1995 AIR INDUSTRIAL PARK ROAD
 GRENADA, MS 38901
 E-MAIL: ADP.FEEDBACK@ADPNOW.COM

Model Nomenclature



W = Wall Mount

Panel Options

- A = Includes upper front panel (embossed)
- B = Includes upper and lower front panel (embossed)
- C = Includes upper front panel (beige)
- D = Includes upper and lower front panel (beige)
- L= Includes upper and lower louvered front panel (beige)

Coil Slab Number

Expansion Device

- 2 = Florator
- 3 = Bleed A/C Expansion Valve R-22
- 4 = Non-Bleed A/C Expansion Valve R-22
- 5 = Non-Bleed HP Expansion Valve R-22
- 6= Non-Bleed A/C Expansion Valve R410a
- 9= Non-Bleed HP Expansion Valve R410a

Nominal BTUH Cooling

18 = 18,000, 24 = 24,000 etc.

Amount of Heat

00 = 0 Kw, 05 = 5 Kw, 07 = 7.5 Kw etc.

Disconnect or line voltage connection

	Available on Kw Heat					
	0	5	7.5	10	12.5	15
S2 = Stripped Wire	#					
P2 = Pull Disconnect		#	#	#		
T2= Terminal Block		*	*	*		
C2 = Circuit Breaker		*	*	*	#	#

= Standard, * = Optional

Performance

Model	Cooling Speed Setting	Wet DX Coil with Filter & Electric Heat				
		CFM vs. ESP (inches H ₂ O)				
		0.1	0.2	0.3	0.4	0.5
W****18	Low	555	546	537	523	487
	Medium	653	634	626	578	578
	High	725	675	640	623	602
W****24	Low	662	648	623	603	563
	Medium	815	786	779	753	730
	High	985	945	906	877	829
W****30	Low	804	782	777	750	722
	Medium	1,009	978	946	900	858
	High	1,129	1,085	1,047	976	925
W****31	Low	1,111	1,076	1,040	991	938
	Medium	1,242	1,189	1,151	1,089	1,016
	High	1,335	1,282	1,221	1,168	1,095
W****36	Low	1,175	1,145	1,116	1,047	985
	Medium	1,333	1,296	1,267	1,242	1,201
	High	1,437	1,412	1,378	1,341	1,291
W****42	Low	1,175	1,145	1,116	1,047	985
	Medium	1,333	1,296	1,267	1,242	1,201
	High	1,437	1,412	1,378	1,341	1,291

*Cooling Speed Settings in Bold are Factory Settings

Clearances to Air Handler

TOP	0"
FRONT*	18"
SIDES	0"
REAR	0"

* Can be less than 18" if front panel is directly behind a louvered closet door; check with local codes and regulations.

Electrical Data

Model	Heating Capacity		Blower Amps		Minimum Circuit Ampacity (2)		Max. Fuse or HACR Bkr.	
	Kw	Mbtuh						
	(1) 240 V	(1) 240 V	208 V	240 V	208 V	240 V	Circuit 1	Circuit 2
18 No Heat	0	0	1.2	1.1	1.5	1.4	15	-
18 Elec. Heat	5.0	17,065	1.2	1.1	24.1	27.4	30	-
18 Elec. Heat	7.5	25,598	1.2	1.1	35.3	40.4	45	-
18 Elec. Heat	10.0	34,130	1.2	1.1	46.6	53.5	60	-
24 No Heat	0	0	2	1.9	2.5	2.4	15	-
24 Elec. Heat	5.0	17,065	2	1.9	25.1	28.4	30	-
24 Elec. Heat	7.5	25,598	2	1.9	36.3	41.4	45	-
24 Elec. Heat	10.0	34,130	2	1.9	47.6	54.5	60	-
30 No Heat	0	0	2.4	2.2	3.0	2.8	15	-
30 Elec. Heat	5.0	17,065	2.4	2.2	25.6	28.8	30	-
30 Elec. Heat	7.5	25,598	2.4	2.2	36.8	41.8	45	-
30 Elec. Heat	10.0	34,130	2.4	2.2	48.1	54.8	60	-
31 No Heat	0	0	2.8	2.6	3.5	3.3	15	-
31 Elec. Heat	5.0	17,065	2.8	2.6	26.1	29.3	30	-
31 Elec. Heat	7.5	25,598	2.8	2.6	37.3	42.3	45	-
31 Elec. Heat	10.0	34,130	2.8	2.6	48.6	55.3	60	-
36 No Heat	0	0	3.2	3.0	4.0	3.8	15	-
36 Elec. Heat	5.0	17,065	3.2	3.0	26.6	29.8	30	-
36 Elec. Heat	7.5	25,598	3.2	3.0	37.8	42.8	45	-
36 Elec. Heat	10.0	34,130	3.2	3.0	49.1	55.8	60	-
36 Elec. Heat	12.5	42,663	3.2	3.0	60.4	68.9	45	30
36 Elec. Heat	15.0	51,195	3.2	3.0	71.7	81.9	60	30
42 No Heat	0	0	3.2	3.0	4.0	3.8	15	-
42 Elec. Heat	5.0	17,065	3.2	3.0	26.6	29.8	30	-
42 Elec. Heat	7.5	25,598	3.2	3.0	37.8	42.8	45	-
42 Elec. Heat	10.0	34,130	3.2	3.0	49.1	55.8	60	-
42 Elec. Heat	12.5	42,663	3.2	3.0	60.4	68.9	45	30
42 Elec. Heat	15.0	51,195	3.2	3.0	71.7	81.9	60	30

kW packages in bold indicates that these heat packages require and include circuit breakers. Optional for others.

(1) For 208 Volts use .751 correction factor for kW & BTUH.

(2) 12.5 & 15Kw (2 stage models) require 2 supply circuits. Circuit #1 includes blower motor amps.

ELECTRICAL WIRING DIAGRAM

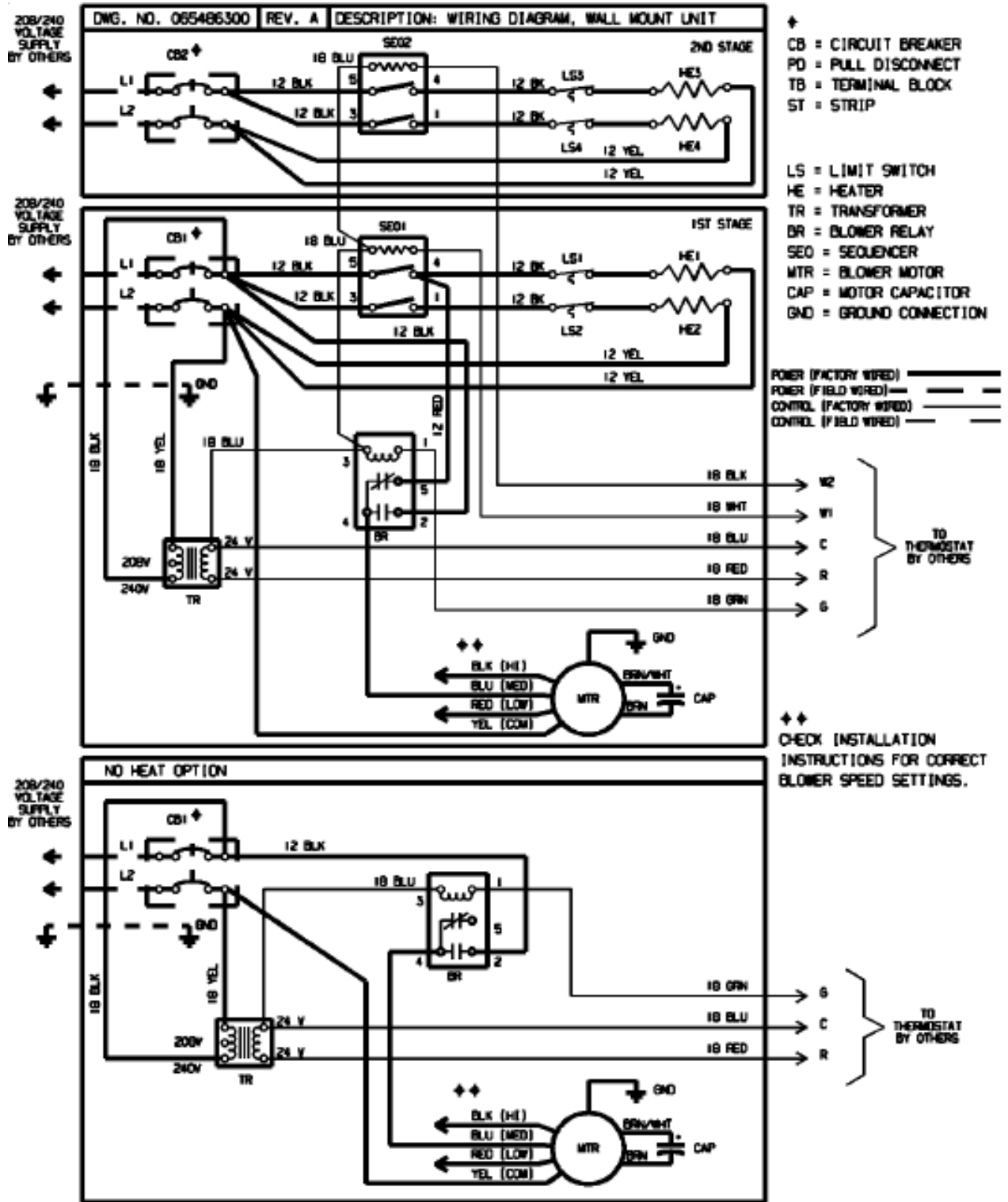

Dimensions

Unit Size	A	B	C	D	E	F	G	Duct Opening
18, 24, 30	15.0"	38 1/2"	11.0"	7.0"	5 1/2"	2 1/4"	3 1/4"	10.0" D X 14.0" W
31, 36, 42	18 3/4"	44 1/2"	14 1/2"	7 3/8"	6.0"	2 1/2"	5 1/2"	12.0" D X 14.0" W

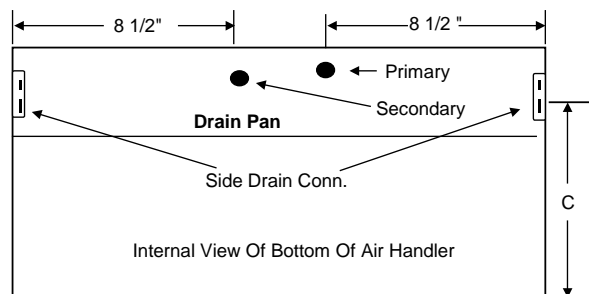
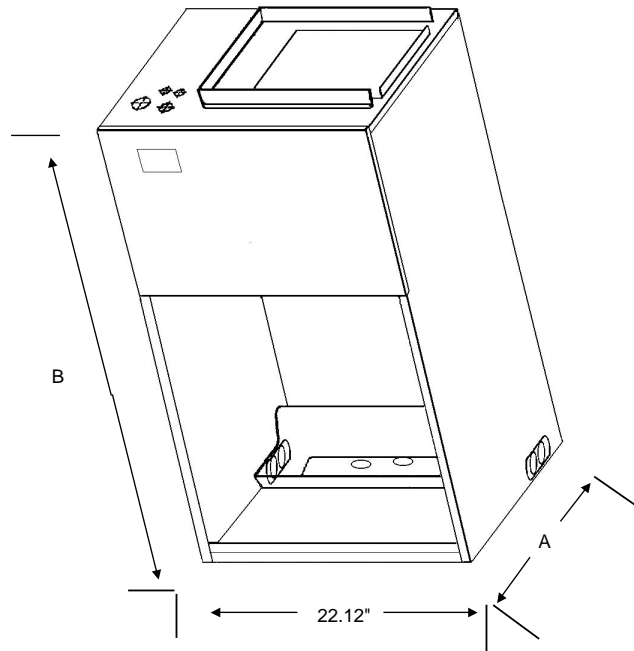
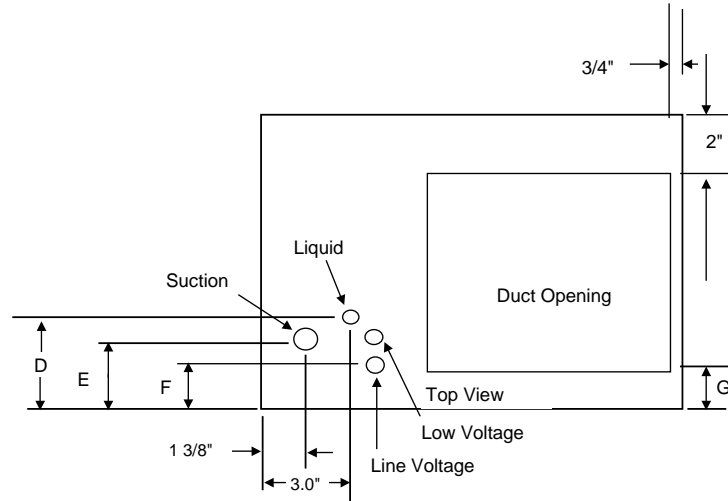

Front



Air Handler Limited Warranty – Standard 5 Year

(Applies only to product installed within the United States or Canada)

Term of Standard Warranty: Advanced Distributor Products (ADP) warrants that products sold shall be of merchantable quality, free of defects in material and workmanship, under normal use and service, for a period of five (5) years from the date of installation, ***not*** to exceed six (6) years from the date of manufacture. Use of this product other than in a residential application will limit the warranted term to a period of (1) year from the date of installation, not to exceed two (2) years from the date of manufacture.

Warranty Procedure: Warranty parts should be replaced by a qualified local contractor or dealer and will require the following information: model number, serial number, date of installation and an accurate description of the problem. Contractor or dealer will contact a local ADP distributor for replacement parts.

Replacement Parts: If, during the term of this warranty, a warranted part fails, ADP will either provide a replacement part free of charge, or may at its option, grant a credit for the original purchase price of the defective article to a distributor of ADP products. ADP may require the return of a defective article for factory inspection to verify and/or determine the root cause of the failure. Covered components include all parts of this unit except for the following ***excluded components***, which are not covered by this warranty: cabinet, cabinet pieces, wiring and wiring harnesses.

Care of Equipment: For this warranty to apply, ADP product must be properly installed, operated, and maintained in accordance with the installation, operation and maintenance instructions provided with each unit. Unauthorized alteration of ADP product may void this warranty.

Conditions of Warranty: Replacement parts furnished under this warranty will be warranted for the balance of the original warranty term of the unit and will not serve to extend the original term. This warranty is void if the ADP product is removed from the original installation site. This warranty does not apply to damage caused by shipping, misuse, mishandling or damage caused by floods, winds, fires, lightning, or exposure to corrosive elements/environments (such as salt, chlorine, fluorine or other damaging chemicals).

Limitations of Warranty: The costs of refrigerant, refrigerant reclamation, miscellaneous material and labor charges for diagnostics, servicing or replacing parts are not covered. ADP shall have no liability for expenses incurred for repairs without prior, written authorization from ADP. No purchaser, distributor, dealer, representative, agent, person, firm or corporation has authority to alter, add to or modify this warranty, either orally or in writing.

No Other Warranties: ADP makes no warranty, express or implied, of fitness for any particular purpose, or of any other nature whatsoever, with respect to products manufactured or sold by ADP hereunder, except as specifically set forth above and on the face hereof. Any implied warranty of merchantability or fitness for a particular purpose on this product is limited in duration to the duration of this warranty. Some states and provinces do not allow limitations on how an implied warranty lasts, so the above limitation may not apply to you. It is expressly understood and agreed that ADP shall not be liable to buyer, or any customer of buyer, for direct or indirect, special, incidental, consequential or penal damages, or for any expenses incurred by reason of the use or misuse by buyer or third parties of said products. To the extent said products may be considered "consumer products", as defined in Sec. 101 of the Magnuson-Moss Warranty-Federal Trade Commission Improvement Act, ADP makes no warranty of any kind, express or implied, to "consumers," except as specifically set forth above on the face hereof. The foregoing is in lieu of all other warranties, express or implied, notwithstanding the provisions of the Uniform Commercial Code, the Magnuson-Moss Warranty-Federal Trade Commission Improvement Act, or any other statutory or common law, federal or state.

2175 West Park Place Boulevard
Stone Mountain, Georgia 30087
www.adpnow.com



Advanced Distributor Products®

Solutions for Your needs

2175 West Park Place Boulevard
Stone Mountain, GA. 30087
www.adpnow.com