

Installation Instructions

MX Series **Indoor Modular Blowers** *Electric or Hot Water Heat*

Table of Contents

AIR HANDLER SAFETY	2	Blower and Coil Assembly	5
INSTALLATION REQUIREMENTS	2	Install Ductwork	6
Tools and Parts	3	Make Electrical Connections	7
Location Requirements	3	Hydronic Coil Installation	9
Installation Configurations	3	Complete Installation	14
Electrical Requirements	5	SEQUENCE OF OPERATION	17
Ductwork Requirements	5	AIR HANDLER MAINTENANCE	18
INSTALLATION INSTRUCTIONS	5	ASSISTANCE OR SERVICE	18
Inspect Shipment	5	WARRANTY	19

! WARNING !

To install the MX Series Air Handler in the horizontal position a (2") clearance must be maintained between the apex of the evaporator coil and the top of the Coil's Cabinet. Therefore, the ADP Multi-position Evaporator Coils listed below cannot be used in the horizontal position with the MX Series Air Handler. The HD Series and V Series dedicated horizontal coils are recommended for these applications.

Model #	— <u>A 0 7</u> —————
Model #	— <u>A 1 5</u> —————
Model #	— <u>E 2 7</u> —————
Model #	— <u>E 3 7</u> —————
Model #	— <u>E 4 8</u> —————
Model #	— <u>E 5 0</u> —————

MX SERIES AIR HANDLER SAFETY

Your safety and the safety of others are very important.

We have provided many important safety messages in this manual and on your appliance. Always read and obey all safety messages.



This is the safety alert symbol. This symbol alerts you to potential hazards that can kill or hurt you and others.

All safety messages will follow the safety alert symbol and either the word "DANGER" or "WARNING." These words mean:



You can be killed or seriously injured if you don't immediately follow instructions.



You can be killed or seriously injured if you don't follow instructions.

All safety messages will tell you what the potential hazard is, tell you how to reduce the chance of injury, and tell you what can happen if the instructions are not followed.

INSTALLATION REQUIREMENTS

These instructions are intended as a general guide only and do not supersede any national or local codes in any way.

Compliance with all local, state, or national codes pertaining to this type of equipment should be determined prior to installation. Read this entire instruction manual, as well as the instructions supplied in separate equipment, before starting the installation. All models are designed for indoor installation only.

The installation of the blower section, field wiring, warm air ducts, etc. must conform to the requirements of the National Electrical Code, ANSI/NFPA No. 70 (latest edition) in the United States, and any state laws, and local ordinances (including plumbing or wastewater codes). Local authorities having jurisdiction should be consulted before installation is made. Such applicable regulations or requirements take precedence over the general instructions in this manual.

Install the conditioned air plenum, ducts and air filters (not provided) in accordance with NFPA 90B Standard for the Installation of Warm Air Heating and Air-Conditioning Systems (latest edition). The blower section is provided with flanges for the connection of the plenum and ducts. Air filters must be listed as Class 2 furnace air filters. The blower section is shipped from the factory completely assembled.

Do not remove the cabinet knockouts until it has been determined which knockouts will need to be removed for the installation.

Select the final installation position that best suits the site conditions. Consider required clearances, space, and routing requirements for refrigerant line, condensate disposal, filters, ductwork, wiring, and accessibility for service. Refer to the rating plate on the blower section for specific information.

WARNING!

This product may contain fiberglass wool insulation. Glass wool fibers are known to the State of California to cause cancer. Disturbing insulation during installation, maintenance, or repair may expose you to glass wool fibers and may cause respiratory, skin or eye irritation. For further information on risks associated with fiberglass wool, consult Material Safety Data Sheet available at OEM.

WARNING



Electrical Shock Hazard

Disconnect power before servicing
Replace all parts and panels before operating.

Electrically ground air handler.

Connect ground wire to ground terminal marked "GRD".

Failure to do so can result in death or electrical shock.



Explosion Hazard

Keep flammable materials and vapors, such as gasoline, away from this unit.

Place this unit so that the heating elements are at least 18 inches (46 cm) above the floor for a garage installation.

Failure to follow these instructions can result in death, explosion, or fire.

Tools and Parts

Gather the required tools and parts before starting installation. Read and follow the instructions provided with any tools listed here.

Tools Needed

- ¼" nut driver
- Level
- Screwdriver
- Adjustable wrench
- Tape Measure
- Hammer
- Sealant
- UL listed wire nuts

Parts Needed

Check local codes, check existing electrical supply, and read "Ductwork Requirements," and "Electrical Requirements," before purchasing parts.

Location Requirements

NOTE: When the unit is installed in a very humid space and used in cooling applications, excessive sweating may occur on outside of unit. To prevent excessive sweating wrap unit with 1" fiberglass insulation. All openings should be sealed to prevent air leakage that could cause condensate to form inside the cabinet.

- If installed in an unconditioned space, sealant should be applied around the electrical wires, refrigerant tubing, and condensate lines where they enter the cabinet.
- Electrical wires should be sealed on the inside where they exit the conduit opening. Sealant is required to prevent air leakage and from condensate from forming inside the blower, control box, and on the electrical controls.
- The blower and its complementing coil must be installed in such a way as to allow free access to the blower/control compartment.
- The blower and its complementing coil must be installed with a ¾" drop in the horizontal position towards the drain pan to ensure proper condensate drainage. The blower and coil should also be tilted ½" from back to front toward the drain line.

IMPORTANT

The Clean Air Act of 1990 bans the intentional venting of refrigerant (CFC's and HFC's) as of July 1, 1992. Approved methods of reclaiming must be followed. Fines and/or incarceration may be levied for non-compliance.

Installation Clearances

Non-Ducted Return Closet Installation

The blower and coil can be installed in a closet with a false bottom to form a return air plenum or be installed with a return air plenum under the coil section.

Louvers or return air grilles are field supplied. Local codes may limit application of systems without a ducted return to single-story buildings.

- For a unit installed in a closet with a louvered return opening, the minimum open area for the louvers will be
 - 320 square inches for 08 models
 - 360 square inches for 12 models
 - 450 square inches for 16 and 20 models
- If the free area is not known, assume a 25% free area for wood or a 75% free area for metal louvers or grilles. Using the louver dimensions and the 25% or 75% assumption, determine if the louver open area meets the minimum open area listed above.
- If the return air plenum is used, the return air grille should be immediately in front of the opening in the plenum to allow for the free flow of return air.
- When not installed in front of the opening, there must be adequate clearance around the MX Series Air Handler to allow for the free flow of return air.

Installation Configurations

For ease in installation, it is best to make any necessary coil configuration changes before connecting the MX Series Air Handler to the coil.

Vertical Installations

Upflow

The blower should be set on top of the coil section being used and the blower must be supported on the bottom only and set on solid floor or a field supplied supporting frame.

Downflow

Turn the Air Handler upside down and place the evaporator coil on top of the blower. Install the two supporting brackets (support brackets are included with all MX Series Air Handlers) between the Air Handler and Evaporator Coil to ensure a proper fit between the two pieces of equipment. The blower must be supported on the bottom only and set on a solid floor or a field supplied supporting frame.

For installations of the MX Series Air Handler with hot water heating in the downflow configuration ensure that there is sufficient space between the plenum and the Air Handler to make the hot water piping connections.

Side Return (Hot water applications only)

Cut and remove panel on the non-motor side, as indicated by perforations.

Attach evaporator coil with sheet metal screws (if using).

Ensure bottom portion of unit is sealed properly to prevent air leakage.

This can be used in an upflow or downflow position.

SIDE RETURN IS NOT APPROVED FOR USE WITH ELECTRIC HEAT.

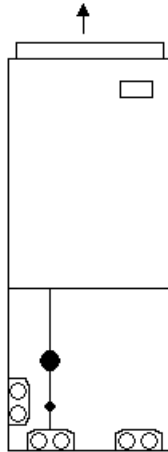

Upflow Configuration with MX Series Air Handler on top of an evaporator coil.

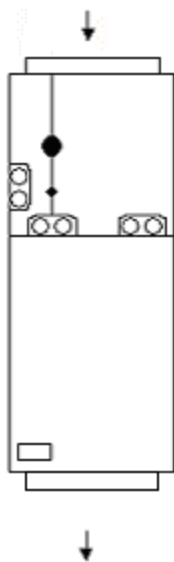

Downflow Configuration with MX Series Air Handler underneath an evaporator coil. Make certain to turn Air Handler Upside Down as shown in the above figure.

Horizontal Installations

Horizontal installations can be left-hand or right-hand air supplied. Adequate support must be provided to ensure cabinet integrity. Ensure that there is adequate room to remove service and access panels if installing in the horizontal position. Refer to instructions provided with coil for proper horizontal installations.

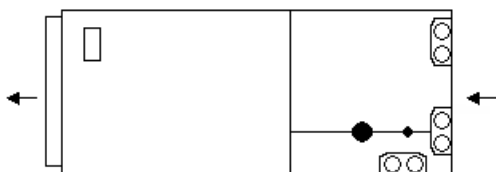

Horizontal Configuration of Blower with a multi-position coil.

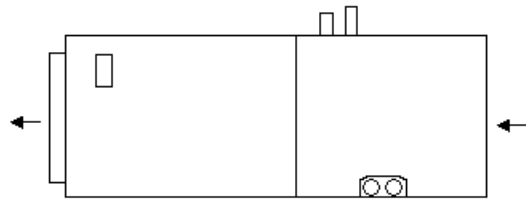

Horizontal Configuration of Blower with an ADP Dedicated Horizontal "A" Coil.

IMPORTANT:

- Refer to the instructions provided with the coil being used to determine how the secondary drain should be trapped and piped.
- When an evaporator coil is installed in an attic or above a finished ceiling, an auxiliary drain pan should be provided under the MX Series Air Handler and coil as specified by most local building codes.

Conversion from Vertical to Horizontal

The MX Series Air Handler can be converted from operating in a vertical to a horizontal position by installing supporting brackets (included with all MX Series Air Handlers) between the two pieces of equipment. A horizontal condensate drain pan (not included with the MX Series Air Handler) would also be needed.

Suspended Cabinet Installation

NOTE: MX Series Air Handlers cannot be installed horizontally lying on or suspended from either the front or back of the MX Series Air Handler. If installed horizontally the blower must be positioned with one side parallel to the floor.

The suspending means must be field fabricated, and should consist of 2 "cradles" made by attaching 2 rods to a length of angle iron or suitable gauge steel.

Electrical Requirements

⚠ WARNING



Electrical Shock Hazard

Disconnect power before servicing
Replace all parts and panels before operating.
Electrically ground air handler.
Connect ground wire to ground terminal marked "GRD".
Failure to do so can result in death or electrical shock.



Explosion Hazard

Keep flammable materials and vapors, such as gasoline, away from this unit.
Place this unit so that the heating elements are at least 18 inches (46 cm) above the floor for a garage installation.
Failure to follow these instructions can result in death, explosion, or fire.

NOTE: Use copper conductors only.

- All field wiring must be done in accordance with National Electrical Code, applicable requirements of UL and local codes, where applicable.
- Electrical wiring, disconnect means and over-current protection are to be supplied by the installer. Refer to the MX Series Air Handler rating plate for maximum over-current protection, minimum circuit ampacity, as well as operating voltage.
- The power supply must be sized and protected according to the specifications supplied on the product.
- This MX Series Air Handler is factory-configured for either 240 Volts or 120 Volts, single phase, 60 cycles. For 208-volt applications, see "208 Volt Conversion" in the "Make Electrical Connections" section.
- Refer to the instructions provided with the accessory for proper installation.

Ductwork Requirements

- Install the conditioned air plenum, ducts and air filters (not provided) in accordance with NFPA 90B Standard for the installation of Warm Air Heating and Air-Conditioning Systems (latest edition).
- The MX Series Air Handler is provided with flanges for the connection of the plenum and ducts.
- Air filters must be listed as Class 2 furnace air filters.
- Supply and return ductwork must be adequately sized to meet the system's air requirements and static pressure capabilities. Ductwork should be insulated with a minimum of 1" thick insulation with a vapor barrier in conditioned areas or 2" minimum in unconditioned areas.

- Supply plenum should be the same size as the flanged opening provided around the blower outlet and should extend ideally at least 3 ft. from the MX Series Air Handler before turning or branching off plenum into duct runs. The plenum forms an extension of the blower housing and minimizes air expansion losses from the blower.

Installation Instructions

Inspect Shipment

The blower section is completely factory assembled, and all components are performance tested. Each unit consists of a blower assembly and controls, in an insulated galvanized steel factory finished enclosure. Knockouts are provided for electrical wiring entrance.

1. Check the unit rating plate to confirm specifications are as ordered.
2. Upon receipt of equipment, thoroughly inspect it for possible shipping damage. Closely examine the unit inside the carton if the carton is damaged.
3. If damage is found, it should be noted on the carrier's freight bill. Damage claims should be filed with carrier immediately. Claims of shortages should be filed with the seller within 5 days.

NOTE: If any damages are discovered and reported to the carrier, do not install the unit because your claim may be denied.

Blower and Coil Assembly

Note: Read and follow coil installation instructions to ensure proper installation of refrigerant lines and drain connections.

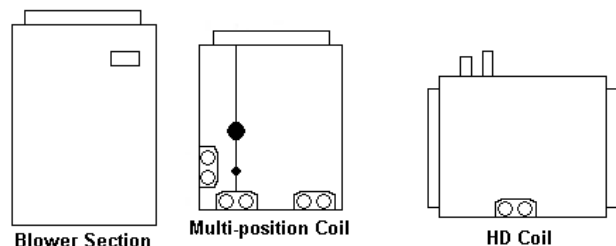

Upflow Configuration

1. Ensure the blower section matches the coil being used.
2. The bottom of the blower section contains a 1/2" gasket. Check to make sure gasket is attached to the bottom of the blower section.
3. Position the blower section over the coil opening or under the coil depending on your desired configuration.
4. The MX is designed to fit perfectly with the ADP "C" depth (20.5") coil. If "E" depth is used, modify the duct flange as follows: with the front of the MX and coil aligned, snip the rear coil flange on each side so that the MX will sit level on the coil (similar to the pictures shown in the section "Horizontal Configuration With Dedicated Horizontal A (HD) Coil."

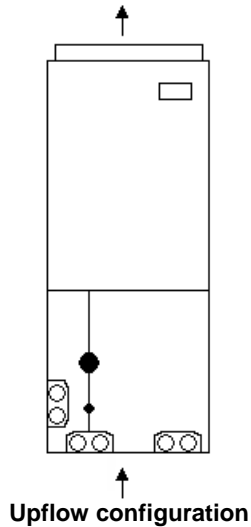

- To secure the MX Series Air Handler fasten the duct flanges of coil with screws to the duct flanges of the blower section.

Horizontal Configuration With Dedicated Horizontal "A" (HD) Coil

- Ensure the proper blower section matches the coil.

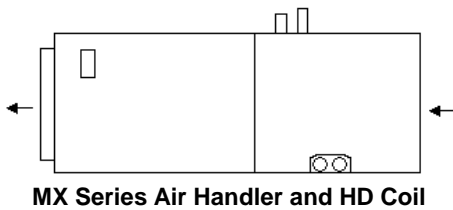

- The bottom of the blower section contains a 1/2" gasket. Check to make sure gasket is attached to the bottom of the blower section.
- Cut a 3/4" slot on the top and bottom flange of the coil. Bend flange on the coil down 90 degrees or you can cut off the flange.



Blower Section (left) and top of coil (right) with 3/4" slot.



Blower Section (left) and bottom of coil (right) with 3/4" slot.

- Position the blower section up against the coil opening.

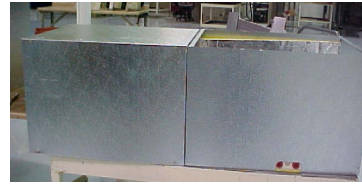

Front of blower (left) connected to a HD coil (right).



Back of HD coil (left) connected to a blower (right).

- Fasten duct flanges of coil to duct flanges of blower section with screws to secure MX Series Air Handler.

Install Ductwork

IMPORTANT:

- Install ductwork in accordance with NFPA 90B and any local codes.
- Connect supply air duct to the flange on top of the blower section of the MX Series Air Handler. If an isolation connector is used, it must be nonflammable.
- Duct connections for the MX Series Air Handler with hot water heat must allow room for water piping connections to be made in upflow and downflow configurations.
- A return air duct system is recommended. If the unit is installed in a confined space or closet, a return connection must be run, full size, to a location outside the closet.

⚠ WARNING



Electrical Shock Hazard

Disconnect power before servicing.
 Replace all parts and panels before operating.
 Electrically ground air handler.
 Connect ground wire to ground terminal marked "GRD".
 Failure to do so can result in death or electrical shock.



Explosion Hazard

Keep flammable materials and vapors, such as gasoline, away from this unit.
 Place this unit so that the heating elements are at least 18 inches (46 cm) above the floor for a garage installation.
 Failure to follow these instructions can result in death, explosion, or fire.

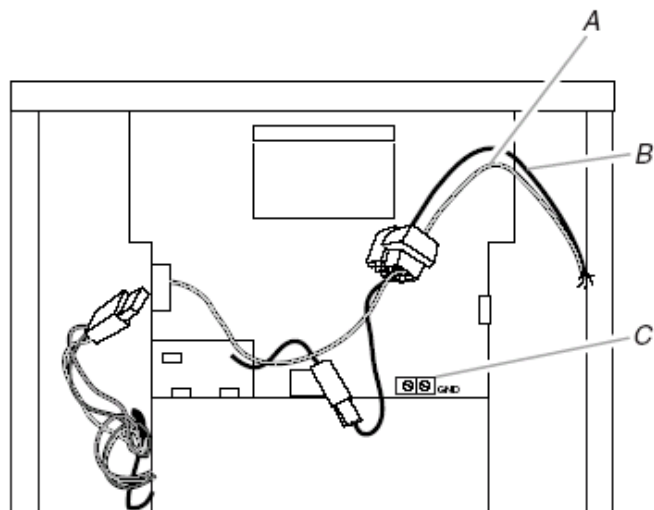

- A. Connect yellow to yellow
- B. Connect black to black
- C. Connect ground wire to ground terminal marked "GND"

Make Electrical Connections

240-Volt or 120 Volt Installations

1. Disconnect all power supplies.
2. Remove the MX Series Air Handler access panel.
3. Route the field supply wires to the MX Series Air Handler electrical connection box.
4. Using UL listed wire nuts; for 240 Volts connect the field supply wires to the MX Series Air Handler (black to black and yellow to yellow). For 120 Volts connect the field supply wires to the MX Series Air Handler (black to black and white to white).

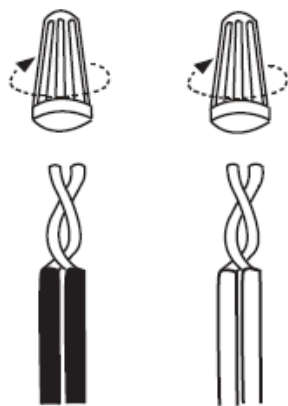

5. Connect ground wire to ground terminal marked "GND."
6. Replace the MX Series Air Handler access panel.

208-Volt Conversion

1. Disconnect all power supplies.
2. Remove the MX Series Air Handler access panel.
3. Move the 2 connected black transformer leads from the 240-volt terminal on the transformer to the 208-volt terminal on the transformer. See "Wiring Diagram – Electric Heat."

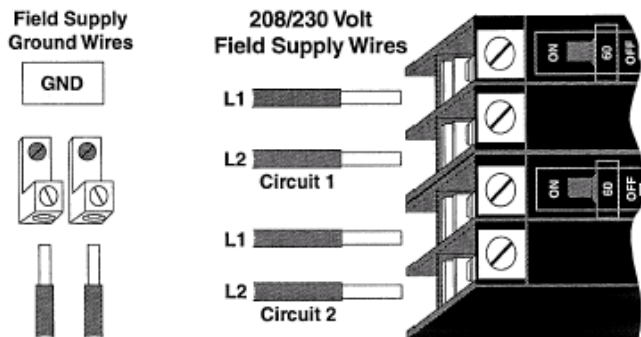

Connect to Terminal Block

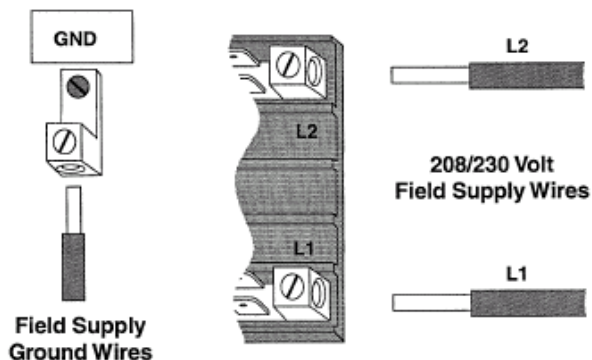

4. Install conduit-opening plugs in any unused openings.
5. If circuit breakers or pull disconnects are used, the front panel knockouts will need to be removed.
6. Reinstall the MX Series Air Handler access panel.
7. Reconnect power.
8. Dispose of/recycle all remaining parts.

Changing Circuit Breaker Orientation

For Air Handlers with Circuit Breaker Line Voltage Connections:

If the MX Series Air Handler is positioned in a horizontal left-hand discharge this position will require no change in the circuit breaker installation orientation. However, if the Air Handler is installed in a horizontal right-hand discharge position, the breaker will need to be installed so that the UP position of the breaker is the ON position. The circuit breaker orientation change is required by UL 1995, Article 26.18 (25 Sep 2005).

⚠ WARNING

Electrical Shock Hazard

Disconnect power before servicing
Replace all parts and panels before operating.
Electrically ground air handler.

Connect ground wire to ground terminal marked "GRD".
Failure to do so can result in death or electrical shock.

Explosion Hazard

Keep flammable materials and vapors, such as gasoline, away from this unit.

Place this unit so that the heating elements are at least 18 inches (46 cm) above the floor for a garage installation.

Failure to follow these instructions can result in death, explosion, or fire.

NOTICE

Copper tubing is recommended, but other approved materials are acceptable.

WARNING!

Solder joints on domestic water lines are to be made with NO-LEAD SOLDER.

NOTICE

The State of MA requires the use of a pump timer on domestic water applications to periodically circulate water during the off cycle. This pump timer requirement is a standard factory installed feature on all MX Series Air Handlers with hot water coils. A 50' maximum distance between water heater and air handler is also required.

NOTICE

In addition to the standard factory installed freeze protection control on all MX Series Air Handlers with hot water heat it is recommended that all water piping be adequately insulated to prevent freezing when piping is run in an unconditioned space, such as attics, crawl spaces, or within structures that may be unoccupied during freezing conditions.

Hydronic Coil Installation

ADP MX Series Air Handlers with hot water heating coils can be used with potable water systems (**Not Approved for potable water systems in the State of MA**) and are shipped with or without circulating pumps. Circulating pump kits are also available for field installation. Refer to pipe and pump sizing in the Air Handler's Engineering & Specification Guide for units with external pumps.

To determine water heater gallon capacity

A minimum 40 gallon high recovery and/or high efficiency gas or oil fired water heater is recommended. The following volume-sizing guide is satisfactory in most areas. Proper water heating sizing should consider both the gallon capacity and the BTU input of the water heater.

1. Determine Volume

CFM	Water Heater Requirements
600-800	40 gallons
1000-1200	40 gallons
1400-1600	Either 2 -40 gallons piped together, 1 high input 50 gallon (63,000 to 75,000 Btu/hr input), or 1 -72 (or higher) gallon tank.
2000	Any combination of water heaters piped together with a total output of 105,000 Btu/hr.

2. Determine water heater BTU/HR input requirements.

Assume water heater recovery efficiency of 76%
 BTU/HR input=
 Mild climates: structure heat loss X 1.51
 Cold climates: structure heat loss X 1.58

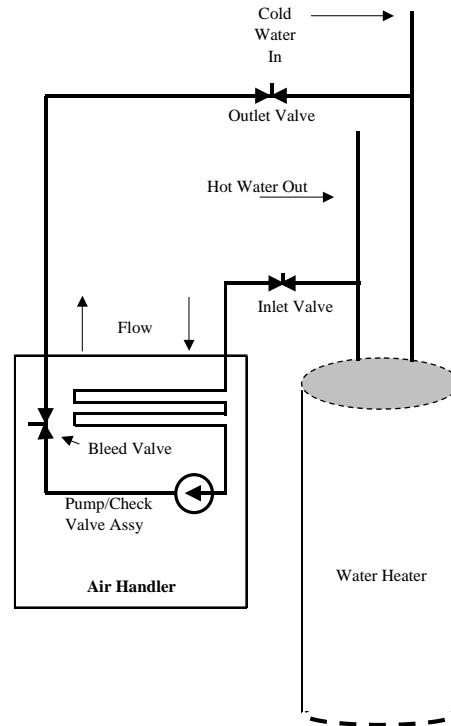

Typical Installation with Domestic Hot Water Heater, many variations on external valves are possible.

Hot Water Coil Water Purging

Purge valves comes standard on all MX Series Air Handlers with hot water coils. Take precautions while purging the Air Handler to keep the Multi-function Control Board and other electrical components from getting wet. Close the supply valve (Inlet) and open the water return (Outlet). Manually open purge valve, use bucket or hose to discard water during purging process. Close the purge valve. Once return line is purged, close return valve (Outlet) and open supply valve (Inlet). Open purge valve, use bucket or hose to discard water during purging process. Close purge valve.

Apply power to the fan coil. Engage pump to verify proper flow direction the right (IN) should be warmer/quicker than the left (OUT).

CAUTION

Open bleed valve while pump is running to remove any residue/deposits left from the installation process. Hot water is preferred in this process. NO CHEMICALS

CAUTION

Do not engage pump until the purge process is completed.

Thermostat Connections - 208/240 Volt

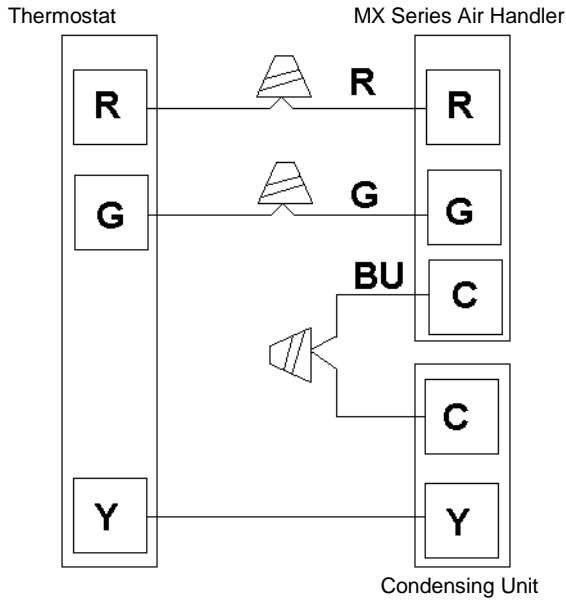

Cooling Only

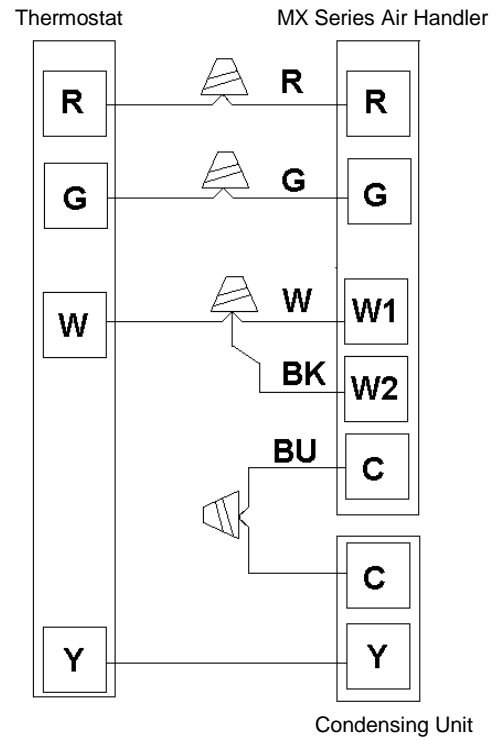

Cooling with Electric Heat (Electric Heat Kits are available for Field Installation Only)

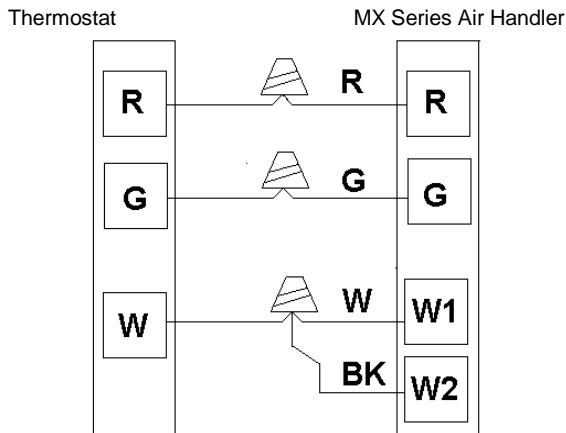

Heating Only (Electric Heat Kits are available for Field Installation Only)

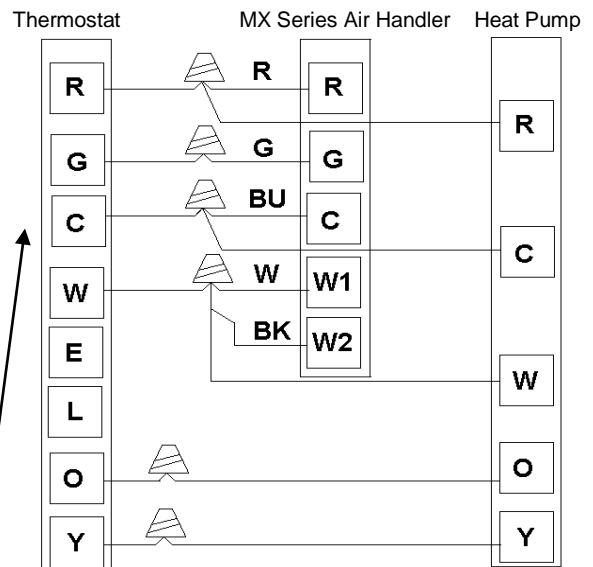

*Connect common (C) wire only if required. See Thermostat Installation Instructions.

Heat Pump with Electric Heat (Electric Heat Kits are available for Field Installation Only)

Thermostat Connections - 120 Volt

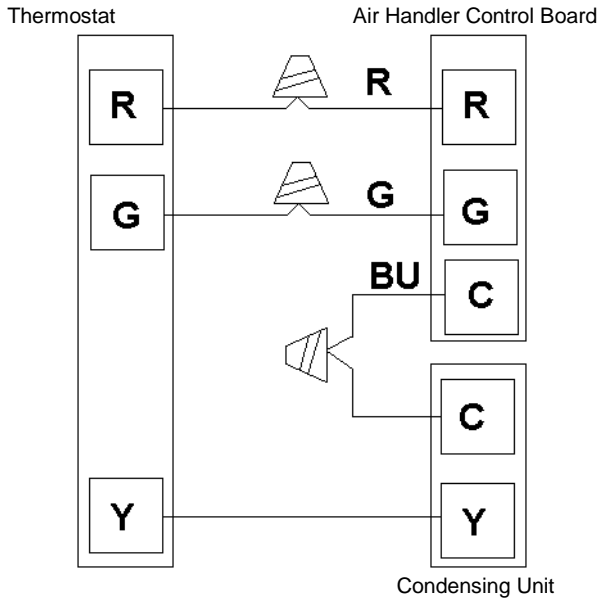

Cooling Only

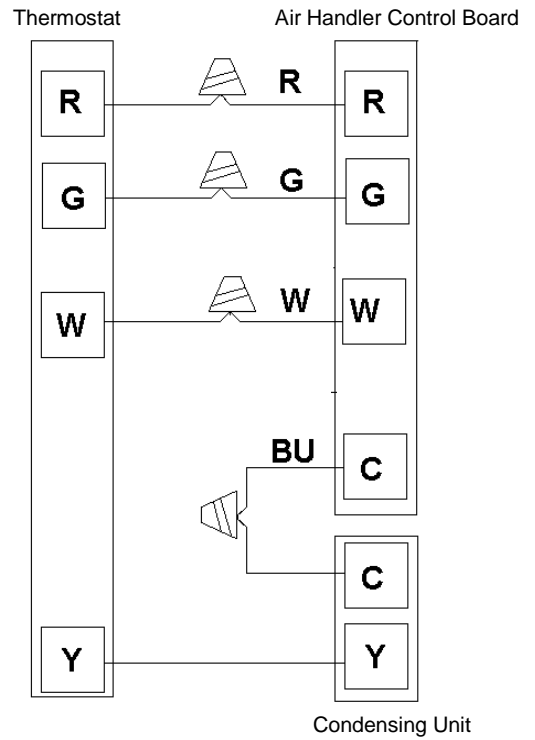

Cooling with Hot Water Heat

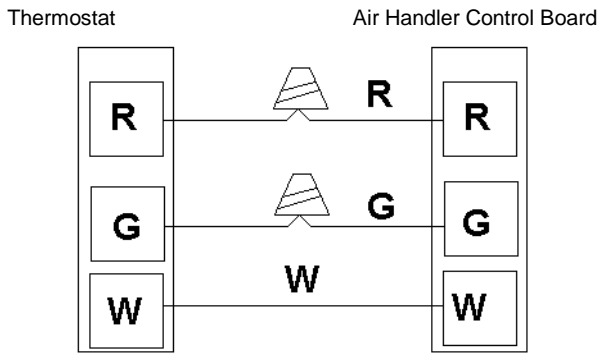

Hot Water Heat Only

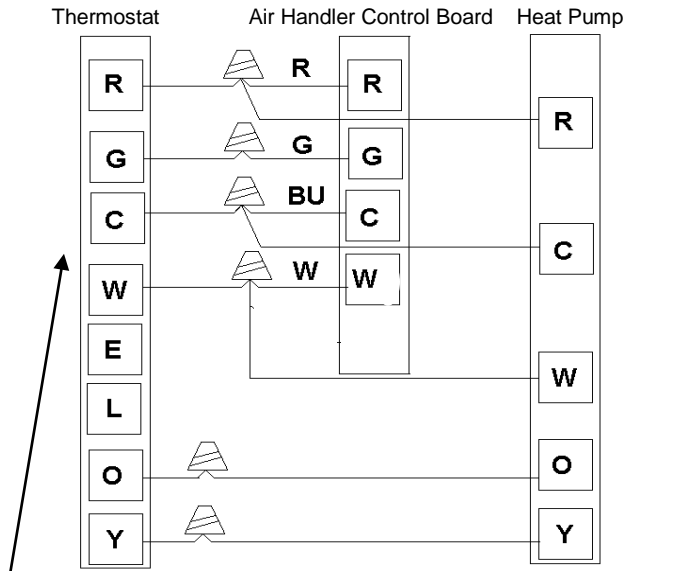

*Connect common (C) wire only if required. See Thermostat Installation Instructions.

Heat Pump with Hot Water Heat

Wiring Diagram-Electric Heat

(Electric Heat Kits are sold separately and are not Factory Installed)

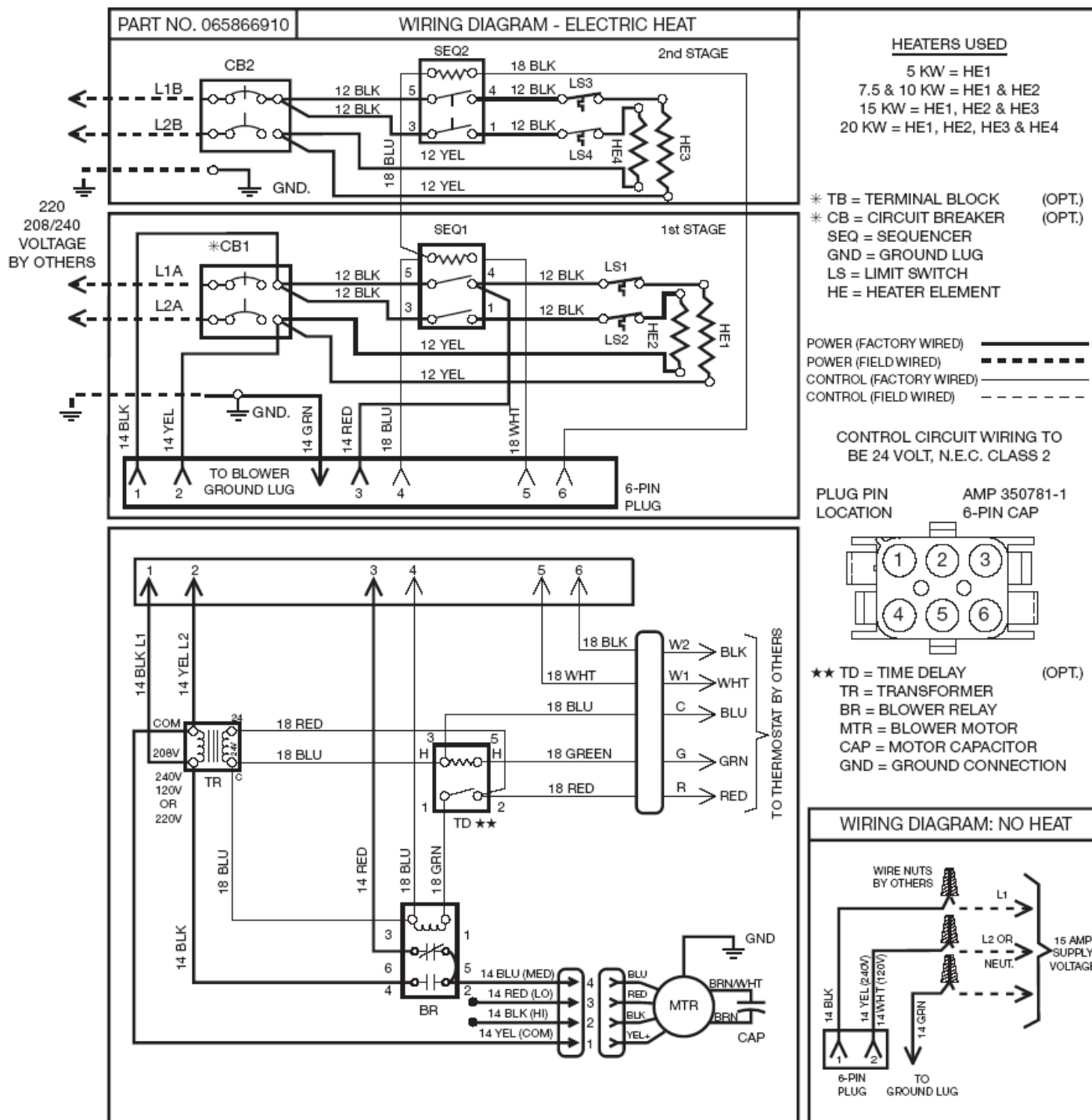

Wiring Diagram-Hot Water Heat

If your unit is equipped with a multi-function control board, then for electric heat installations insure that heat selector pin is set to "E".

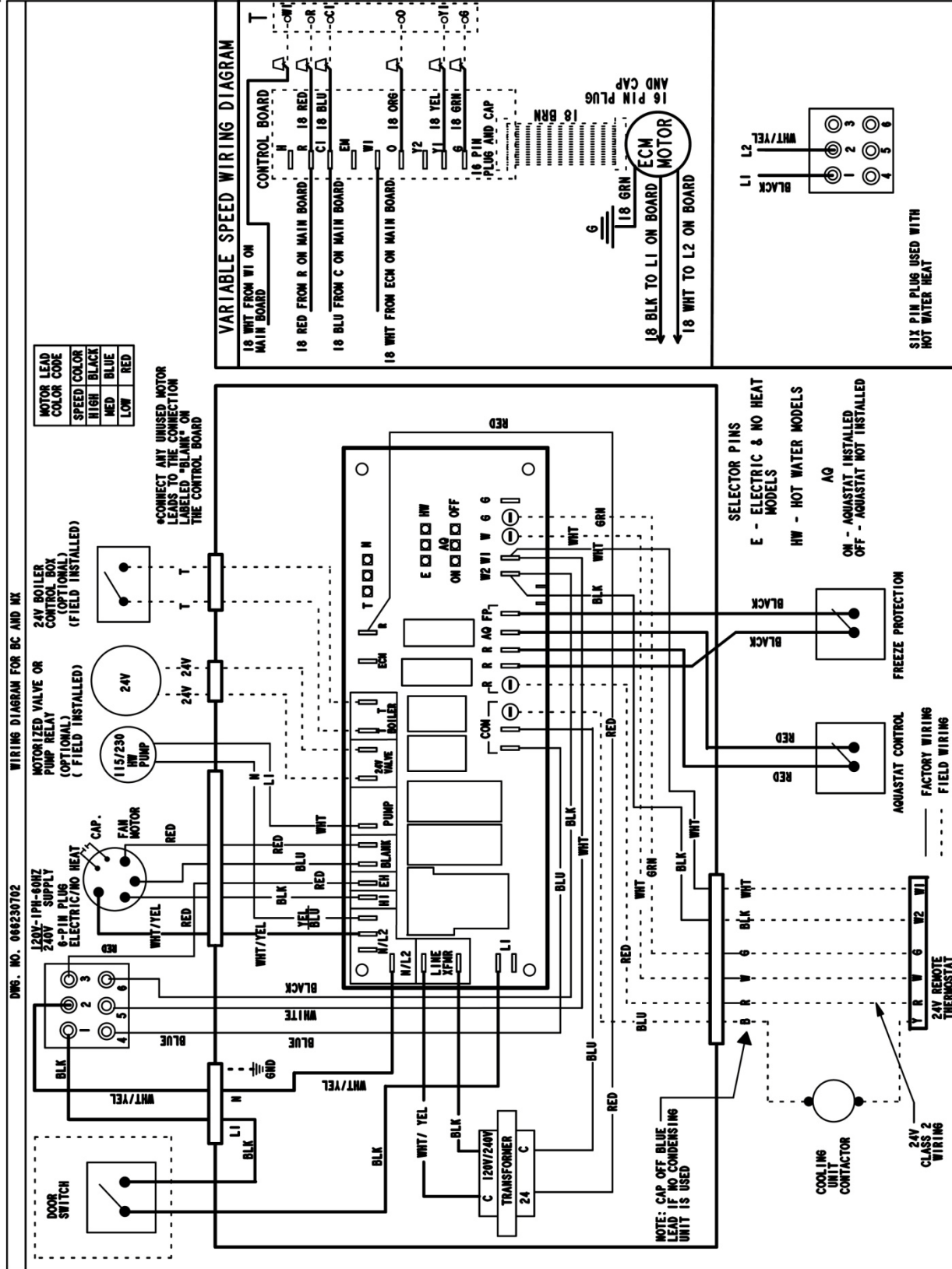

Complete Installation

NOTE: Refer to outdoor unit installation instructions for system start-up instructions and refrigerant charging instructions.

PRE-Start Check

- Is unit properly located, secure, and serviceable? Does the MX Series Air Handler and Evaporator Coil exhibit a $\frac{3}{4}$ " pitch in the horizontal position towards the drain pan to ensure proper condensate drainage?
- Has an auxiliary pan been provided under the unit with separate drain for units installed above a finished ceiling or in any installation where condensate overflows could cause damage?
- Have all webs been removed from the drain connections that are being used? Have all drain pan plugs not used been properly plugged?
- Has the condensate line been properly sized, run, trapped, pitched, and tested?
- Is the ductwork correctly sized, run, taped, and insulated?
- Have all cabinet openings and wiring been sealed?
- Is the indoor coil orifice size correct?
- Have all unused orifice replacement parts and packaging been disposed of or recycled?
- Is the filter clean, in place, and of adequate size?
- Is the wiring neat, correct, and in accordance with the wiring diagram?
- Is the unit properly grounded and protected (fused)?
- Is the thermostat correctly wired and in a good location?
- Are all access panels in place and secure?

Check Blower Operation

1. Set the thermostat to FAN ON.
2. The indoor blower should come on.

Check Electric Heater (if used)

1. Set thermostat to call for auxiliary heat (approximately 5°F above ambient temperature). The indoor blower and auxiliary heat should come on together. Allow a minimum of 3 minutes for all sequencers to cycle on.
2. Set the thermostat so it does not call for heat. Allow up to 5 minutes for all sequencers to cycle off.

Check/Change Airflow

- For proper cooling operation, the airflow through the indoor coil should be between 350 and 450 CFM per ton of cooling capacity (or 350 – 450 CFM per 12,000 BTU/HR) based on the rating of the outdoor unit.
- The cooling blower speed is factory configured to provide correct airflow for an outdoor unit that matches the maximum cooling capacity rating of the MX Series Air Handler.
- If the outdoor unit is smaller than the maximum cooling capacity rating for the MX Series Air Handler, the cooling blower speed may need to be changed. Refer to Blower Performance Chart.

IMPORTANT: The cooling blower speed must be set to provide a minimum of 350 CFM airflow per ton (12,000 BTU/HR) of outdoor cooling capacity.

⚠ WARNING



Electrical Shock Hazard
Disconnect power before servicing
Replace all parts and panels before operating.
Electrically ground air handler.
Connect ground wire to ground terminal marked "GRD".
Failure to do so can result in death or electrical shock.



Explosion Hazard
Keep flammable materials and vapors, such as gasoline, away from this unit.
Place this unit so that the heating elements are at least 18 inches (46 cm) above the floor for a garage installation.
Failure to follow these instructions can result in death, explosion, or fire.

MAXIMUM KW FOR UNITS WITH NOMINAL CFM SET AT 1400 (3.5 TONS) IS 15 KW.

NOTE: IF NOMINAL CFM IS SET AT 1000 (2.5 TONS) WITH 15 KW ELECTRIC HEAT, THE MOTOR SPEED MUST BE SET AT MEDIUM OR HIGHER.

To change blower speed: Refer to "Wiring Diagram – Electric Heat" or "Wiring Diagram – Hot Water Heat," depending on which application is being used.

Models with 208/240 V, 60 Hz Supply Voltage

1. Disconnect all power supplies
2. Remove the MX Series Air Handler access panel.
3. Locate pin number 2 on the blower relay. Two black wires are connected to this terminal pin. One connects to pin number 5 on the blower relay; one connects to an inline splice connecting to a red or blue wire.
4. Remove the wire going to the 4-pin blower motor connector from the splice.
5. Connect the blower lead (Red (LO), Black (HI)) onto the splice from the 4-pin blower motor connector.
NOTE: Unused blower speeds are shipped from the factory covered with a plastic cap. Remove this cap from the new blower speed terminal and replace it over the factory – set blower terminal.
6. Replace all panels and reconnect power.

Models 08, 12, & 20 with 120 V Supply Voltage

1. Disconnect all power supplies.
2. Remove the air handler access panel.
3. Locate the blue wire (Med) running from the blower motor to the control board.
4. Remove this blue wire from the control board and cover this loose end of this wire now with an insulating cap.
5. Locate the Red or Black wires connected to the blower motor. Connect the Red (Low) to the control board at its respective terminal for low speed or connect the Black (High) to the control board at its respective terminal for high speed.
6. Replace all panels.
7. Reconnect power.

Model 16 with 120 V Supply Voltage

1. Disconnect all power supplies.
2. Remove the air handler access panel.
3. Locate the black wire (High) running from the blower motor to the control board.
4. Remove this black wire from the control board and cover this loose end of this wire now with an insulating cap.
5. Locate the Blue or Red wires connected to the blower motor. Connect the Blue (Med) to the control board at its respective terminal for medium speed or connect the Red (Low) to the control board at its respective terminal for low speed.
6. Replace all panels.
7. Reconnect power.

Instructions for Field Installed Aquastats - Hot Water Heat

(See Sequence of Operations for Factory Installed Aquastat Instructions)

When selecting the proper relay (drawing below) to attach with an aquastat be sure that the relay is capable of the maximum amp draw required by the Air Handler. For all external aquastats used in conjunction with this Air Handler please follow the installation instructions provided per the manufacturer of the aquastat.

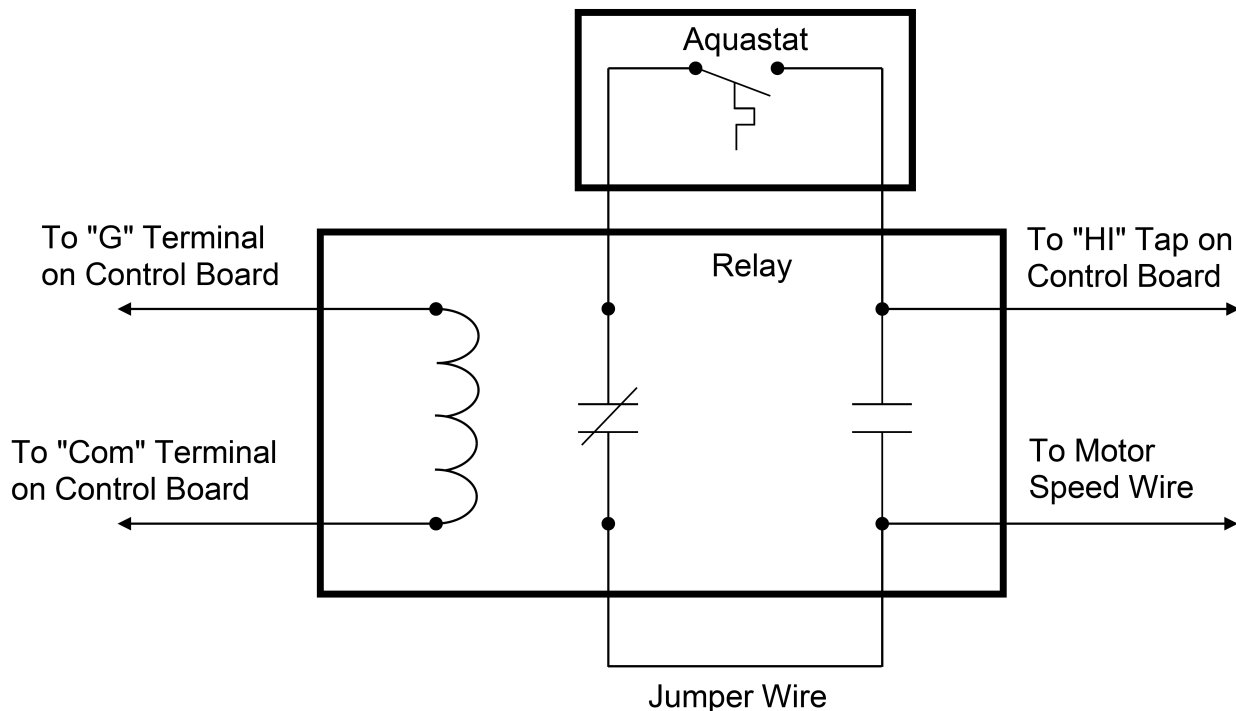

MX Series Blower Performance Data w/ Electric Heat

Blower Size	Blower Speed	CFM vs. ESP "WC				
		0.1	0.2	0.3	0.4	0.5
08	Low	591	601	586	564	513
	*Med	914	881	832	773	699
	High	1077	1020	947	874	768
12	Low	1085	1076	1059	1043	1009
	*Med	1260	1255	1252	1207	1168
	High	1335	1330	1326	1289	1252
16	Low	1512	1487	1444	1399	1315
	Med	1635	1605	1585	1503	1416
	*High	1732	1703	1635	1555	1471
20	Low	1604	1582	1548	1490	1417
	*Med	2064	1993	1907	1817	1709
	High	2218	2131	2039	1943	1829

MX Series Blower Performance Data w/ Hot Water Heat

Blower Size	Blower Speed	CFM vs. ESP "WC				
		0.1	0.2	0.3	0.4	0.5
08	Low	749	705	658	614	558
	*Med	865	815	760	708	646
	High	904	836	801	740	681
12	Low	1198	1144	1086	1018	962
	*Med	1257	1198	1130	1072	1010
	High	1273	1215	1158	1094	1018
16	Low	1576	1514	1433	1338	1264
	Med	1643	1576	1490	1407	1320
	*High	1707	1606	1545	1441	1364
20	Low	1759	1691	1652	1580	1512
	Med	1838	1788	1729	1644	1555
	*High	1928	1867	1810	1729	1637

Speeds marked in **bold with an asterisk*** are the factory speed settings for both heating and cooling. All data is given while air handler is operating with a dry DX coil and air filter installed. these are nominal values and blower performance can vary higher or lower from these values based on the evaporator coil that is used. Hot water heat airflow data includes associated air pressure drop across a 4 row hot water coil for Unit Size 08, 12 & 16; air pressure drop across a 3 row hot water coil for Unit Size 20.

Sequence of Operations 208/240 V, 60 Hz Supply Voltage Models

Cooling

When the thermostat calls for cooling, the circuit between R and G is completed, and the blower relay is energized. The Normally Open contacts close, causing the indoor blower motor to operate. The circuit between R and Y is also completed; this circuit closes the contactor in the outdoor fan motor. Circuit R and O or R and B energizes the reversing valve, switching it to the cooling position (depends on outdoor unit). Air Handler blower turns off 45 seconds after the thermostat stops calling for cooling.

Heating (electric heat only)

When the thermostat calls for heat, the circuit between R and W is completed, and the heater sequencer is energized. A time delay follows before the heating elements and the indoor blower motor comes on. Units with a second heat sequencer can be connected with the first sequencer to W on the thermostat sub base or connected to a second stage on the sub base. Air Handler blower turns off 30 seconds after the thermostat stops calling for heating.

Heating (heat pump with electric heat)

When the thermostat calls for heat, the circuits between R and Y and R and G are completed. Circuit R-Y energizes the contactor starting the outdoor fan motor and the compressor. Circuit R and G energizes the blower relay starting the indoor blower motor. Circuit R and O or R and B energizes the reversing valve, switching it to the heating position (depends on outdoor unit). If the room temperature should continue to fall, the circuit between R and W1 is completed by the second stage heat room thermostat. Circuit R-W1 energizes a heat sequencer. The completed circuit will energize supplemental electric heat (if applicable). Units with a second heater sequencer can be connected with the first sequencer to W1 on the thermostat or connected to a second heating stage W2 on the thermostat sub base. Air Handler blower turns off 30 seconds after the thermostat stops calling for heating.

Emergency Heat (heat pump with electric heat)

If selector switch on thermostat is set to the emergency heat position, the heat pump will be locked out of the heating circuit, and all heating will be electric heat (if applicable). A jumper should be placed between W2 and E on the thermostat subbase so that the electric heat control will transfer to the first stage heat on the thermostat. This will allow the indoor blower to cycle on and off with the electric heat when the fan switch is in the AUTO position.

Sequence of Operations Hot Water Heat Models

The Blower Door Safety Switch circuit must be complete for all Sequence of Operations to take place.

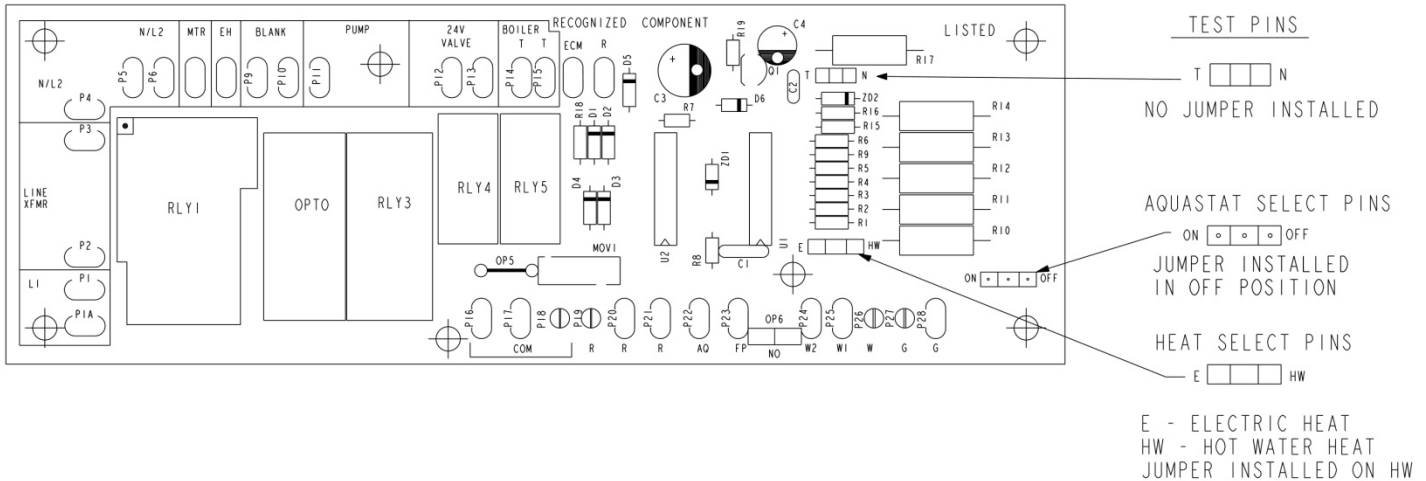

Drawing of Multi-function Control Board, factory installed in all MX Series Air Handlers with hot water heat.

!!Please take precautions while installing the Air Handler to keep Multi-function Control Board and other controls from getting wet!!

Cooling

When the thermostat calls for cooling, the circuit between R and G is completed. The normally open contacts close, causing the indoor blower motor to operate. The circuit between R and Y is also completed; this circuit closes the contactor in the outdoor fan motor. Circuit R and O or R and B energizes the reversing valve, switching it to the cooling position (depends on outdoor unit). The Air Handler fan will turn off 45 seconds after the Thermostat stops calling for cooling.

Heating (hot water heat only)

When the thermostat calls for heat, the circuit between R and W is completed, activating the hot water circulating pump. If a field installed circulating pump is being used the control board can still be wired to the pump directly or to an isolation valve supplying hot water to the Air Handler using the control board's 24V relay switch. A similar 24 V dry switching relay labeled TT can be used to activate a boiler or water heater valve. After the circuit between R & W are completed

1. Units with Factory Installed Aquastats- The water temperature inside the hot water coil must reach 130 deg. F before the circuit between R and G are complete activating the indoor blower motor. To deactivate a factory installed aquastat simply move the selector pin on the multi-function control board (See drawing above) from the on position to the off position.
2. Units without Factory Installed Aquastats or Deactivated Aquastats- A time delay of 60 seconds follows before the circuit between R and G are complete activating the indoor blower motor.

The Air Handler fan will turn off 30 seconds after the Thermostat stops calling for heating.

Heating (heat pump with hot water heat)

When the thermostat calls for heat, the circuits between R and Y and R and G are completed. Circuit R-Y energizes the contactor starting the outdoor fan motor and the compressor. Circuit R and G energizes the blower relay starting the indoor blower motor. Circuit R and O or R and B energizes the reversing valve, switching it to the cooling position (depends on outdoor unit). If the room temperature should continue to fall, the second stage heat room thermostat completes the circuit between R and W. If a field installed circulating pump is being used the control board can still be wired to the pump directly or to an isolation valve supplying hot water to the Air Handler using the control board's 24V relay switch. A similar 24 V dry switching relay labeled TT can be used to activate a boiler or water heater valve. After the circuit between R & W are completed

1. Units with Factory Installed Aquastats- The water temperature inside the hot water coil must reach 130 deg. F before the circuit between R and G are complete activating the indoor blower motor. To deactivate a factory installed aquastat simply move the selector pin on the multi-function control board (See drawing above) from the on position to the off position.
2. Units without Factory Installed Aquastats or Deactivated Aquastats- A time delay of 60 seconds follows before the circuit between R and G are complete activating the indoor blower motor.

The Air Handler fan will turn off 45 seconds after the Thermostat stops calling for heating.

Freeze Protection (hot water heat)

If the temperature of the water within the hot water coil were to drop below 40°F the circuit between R and W is completed, activating the hot water circulating pump, external circulating pump or isolation valve. Once the water temperature rises above 70°F the circuit between R and W is opened and hot water will stop circulating within the hot water coil.

Pump Timer (hot water heat)

The State of Massachusetts requires the use of a pump timer on domestic water applications to periodically circulate water during the off cycle. This pump timer requirement is a standard factory installed feature on all MX Series Air Handlers with hot water heat. The Pump timer activates the circulating pump or isolation valve for one minute every six hours by completing the circuit between R and W. The Pump timer is skipped while the outdoor compressor is operating.

MX Series Air Handler Maintenance

At the beginning of each heating season the unit should be serviced by a qualified installer or servicing agency.

Assistance or Service

If you need further assistance, you may contact us at the address below or e-mail us with any questions or concerns. Please include a daytime phone number in your correspondence.

Advanced Distributor Products
1995 Air Industrial Park Road
Grenada, MS 38901

Air Handler Limited Warranty – Standard 5 Year

(Applies only to product installed within the United States or Canada)

Term of Standard Warranty: Advanced Distributor Products (ADP) warrants that products sold shall be of merchantable quality, free of defects in material and workmanship, under normal use and service, for a period of five (5) years from the date of installation, ***not*** to exceed six (6) years from the date of manufacture. Use of this product other than in a residential application will limit the warranted term to a period of (1) year from the date of installation, not to exceed two (2) years from the date of manufacture.

Warranty Procedure: Warranty parts should be replaced by a qualified local contractor or dealer and will require the following information: model number, serial number, date of installation and an accurate description of the problem. Contractor or dealer will contact a local ADP distributor for replacement parts.

Replacement Parts: If, during the term of this warranty, a warranted part fails, ADP will either provide a replacement part free of charge, or may at its option, grant a credit for the original purchase price of the defective article to a distributor of ADP products. ADP may require the return of a defective article for factory inspection to verify and/or determine the root cause of the failure. Covered components include all parts of this unit except for the following ***excluded components***, which are not covered by this warranty: cabinet, cabinet pieces, wiring and wiring harnesses.

Care of Equipment: For this warranty to apply, ADP product must be properly installed, operated, and maintained in accordance with the installation, operation and maintenance instructions provided with each unit. Unauthorized alteration of ADP product may void this warranty.

Conditions of Warranty: Replacement parts furnished under this warranty will be warranted for the balance of the original warranty term of the unit and will not serve to extend the original term. This warranty is void if the ADP product is removed from the original installation site. This warranty does not apply to damage caused by shipping, misuse, mishandling or damage caused by floods, winds, fires, lightning, or exposure to corrosive elements/environments (such as salt, chlorine, fluorine or other damaging chemicals).

Limitations of Warranty: The costs of refrigerant, refrigerant reclamation, miscellaneous material and labor charges for diagnostics, servicing or replacing parts are not covered. ADP shall have no liability for expenses incurred for repairs without prior, written authorization from ADP. No purchaser, distributor, dealer, representative, agent, person, firm or corporation has authority to alter, add to or modify this warranty, either orally or in writing.

No Other Warranties: ADP makes no warranty, express or implied, of fitness for any particular purpose, or of any other nature whatsoever, with respect to products manufactured or sold by ADP hereunder, except as specifically set forth above and on the face hereof. Any implied warranty of merchantability or fitness for a particular purpose on this product is limited in duration to the duration of this warranty. Some states and provinces do not allow limitations on how an implied warranty lasts, so the above limitation may not apply to you. It is expressly understood and agreed that ADP shall not be liable to buyer, or any customer of buyer, for direct or indirect, special, incidental, consequential or penal damages, or for any expenses incurred by reason of the use or misuse by buyer or third parties of said products. To the extent said products may be considered "consumer products", as defined in Sec. 101 of the Magnuson-Moss Warranty-Federal Trade Commission Improvement Act, ADP makes no warranty of any kind, express or implied, to "consumers," except as specifically set forth above on the face hereof. The foregoing is in lieu of all other warranties, express or implied, notwithstanding the provisions of the Uniform Commercial Code, the Magnuson-Moss Warranty-Federal Trade Commission Improvement Act, or any other statutory or common law, federal or state.

2175 West Park Place Boulevard
Stone Mountain, Georgia 30087
www.adpnow.com



Advanced Distributor Products[®]

Solutions for Your needs

2175 West Park Place Boulevard
Stone Mountain, GA 30087
www.adpnow.com